

★
AN 16-45-223

**HANDBOOK
OVERHAUL INSTRUCTIONS**

RADIO RECEIVER

MODEL SP-600-JX

(HAMMARLUND)

FREE DOWNLOAD

COURTESY OF NBSOR

WWW.HAMMARLUND.ORG

PUBLISHED UNDER AUTHORITY OF THE SECRETARY OF THE AIR FORCE
AND THE CHIEF OF THE BUREAU OF AERONAUTICS

Reproduction for non-military use of the information or illustrations contained in this publication is not permitted without specific approval of the issuing service (BuAer or USAF). The policy for use of Classified Publications is established for the Air Force in AFR 205-1 and for the Navy in Navy Regulations, Article 1509.

LIST OF REVISED PAGES ISSUED

INSERT LATEST REVISED PAGES. DESTROY SUPERSEDED PAGES.

NOTE: The portion of the text affected by the current revision is indicated by a vertical line in the outer margins of the page.

FREE DOWNLOAD

COURTESY OF N9SOR

WWW.HAMMARLUND.ORG

* The asterisk indicates pages revised, added or deleted by the current revision.

ADDITIONAL COPIES OF THIS PUBLICATION MAY BE OBTAINED AS FOLLOWS:

USAF ACTIVITIES.—In accordance with Technical Order No. 00-5-2.
NAVAL ACTIVITIES.—Use Publications and Forms Order Blank (NavAer 2126) and submit to the nearest publications supply point listed below: NAS, Alameda, Calif.; NAS, Jacksonville, Fla.; NAS, Norfolk, Va.; NAS, San Diego, Calif.; NAS, Seattle, Wash.; NASD, ASO, Guam; NASD, Philadelphia, Pa.
For listing of available publications see Naval Aeronautic Publications Index (NavAer 00-500).

USAF

TABLE OF CONTENTS

Section	Page	Section	Page
I DESCRIPTION AND LEADING PARTICULARS		VII REPAIR AND REPLACEMENT	
1- 1. General	1	7- 1. General	13
1- 3. Pertinent Information	1	7- 2. Switch Base and Spring Assembly	13
II SPECIAL OVERHAUL TOOLS AND TEST EQUIPMENT		7- 3. Selectivity Switch	13
2- 1. Special Tools	2	7- 4. Retropicalization	13
2- 3. Special Test Equipment	2	VIII REASSEMBLY AND TESTING OF SUB-ASSEMBLIES AND ASSEMBLIES	
III SPECIALIZED MAINTENANCE AND REPAIR		8- 1. Reassembly	14
3- 1. General	3	8- 2. Reassembly of Tuning Unit Assembly	14
3- 5. Specialized Maintenance of Parts	3	8- 3. Resoldering and Retropicalization	15
IV DISMANTLING AND DISASSEMBLY		8- 4. Testing of Subassemblies and Assemblies	15
4- 1. Preliminary Procedure	4	IX REASSEMBLY AND TESTING OF COMPONENTS	
4- 2. Dismantling of Tuning Unit Assembly	4	9- 1. Reassembly	15
4- 4. Disassembly of Gear Train Assembly	6	9- 2. Reassembly of the Chassis and Tuning Unit Assembly	15
4- 5. Chassis Disassembly	6	9- 3. Reassembly of the Chassis and Panel Assembly	16
V CLEANING		9- 4. Reassembly of the Radio Receiver	16
5- 1. Overall	7	9- 5. Reassembly of the RF Tuners	16
5- 3. Electrical Parts	7	9- 6. Testing	17
5- 5. Mechanical Parts	7	X FINAL ASSEMBLY	
5- 8. Preservation After Cleaning	7	10-1. General	17
VI INSPECTION		XI INSPECTION AND TESTING	
6- 1. General	8	11-1. General	17
6- 3. Inspection Technique	8	11-2. Minimum Performance and Test Values	17
6- 4. Receiver Abnormalities	8	INDEX	18
6- 5. Receiver Inspection	8		
6- 8. Subassembly Inspection	8		
6-10. Parts Inspection	8		
6-29. Functional Mechanical Parts	12		
6-30. Mechanical Performance Standards	12		
6-31. Life of the Receiver	12		
6-32. Service Limits	12		

LIST OF ILLUSTRATIONS

Figure	Page	Figure	Page
1-1. Radio Receiver, Model SP-600-JX Rack Mountings	ii	2-3. Special Tools to Reassemble Turret Rotor Assembly	2
2-1. Special Tools to Reassemble RF Strip Assembly	2	2-4. Special Tools to Reassemble Gear Train Assembly	2
2-2. Special Tools to Reassemble Tuning Unit Shield Assembly	2	4-1. Gear Train Assembly, Exploded View	5

LIST OF TABLES

Table	Page
2-1. Special Tools Required for Overhaul	1
9-1. Identification of the r-f Tuners	16



Figure 1-1. Radio Receiver, Model SP-600-JX Rack Mountings

SECTION I

DESCRIPTION AND LEADING PARTICULARS

1-1. GENERAL.

1-2. This publication comprises overhaul instructions for the Radio Receiver, Model SP-600-JX rack mounting (See figure 1-1.), manufactured by the Hammarlund Mfg. Co. New York 1, N.Y. The receiver, designed for direct mounting in a standard 19-inch relay rack, is a 20-tube general purpose radio communication receiver with a self-contained stabilized power supply suited to operate from a single phase 50- to 60- cps, 90 to 270 volt a-c source. It provides for the continuously variable or crystal controlled fixed frequency reception of any radio frequency carrier in the 0.54 to 54.0 mc frequency range. The rotary turret which houses the six frequency bands of the receiver, in association with the gear-train drive, provide for the excellent mechanical stability for which the receiver is known. Also, its precise mechanical construction enables full advantage to be derived from the crystal filter incorporated in the i-f amplifier of the receiver. The receiver functional circuitry is mostly contained in sub-assemblies, all of which may be subjected to individual replacement whenever the need arises for receiver repair. The receiver is designed for fixed and/or mobile operational activities such as are encountered at enclosed base or field stations, on ship-board, or when airborne. Such activities may be subject to wide ranges in temperature and humidity since the receiver is adequately conditioned for tropical use. The receiver is fully shielded to keep its radiation characteristics to a possible minimum.

1-3. PERTINENT INFORMATION.

1-4. The radio receiver is suited to operate in single or multi-receiver two-way operational activities. Any activity requires that certain auxiliary components be associated with the receiver. Apart from the phone jack contained in the front panel of the receiver, all the receiver inter-connecting means are located on the rear apron. The rear apron also contains two fuse holders, one for a three ampere cartridge type fuse in series with the power transformer primary winding, and the other for a duplicate spare. The power transformer secondary plate winding is fused by a three-eighths ampere pigtail type fuse soldered between the transformer terminal 11 and chassis ground. The front panel of the receiver contains all the receiver operating controls. All the receiver adjustment controls are located on the rear apron. The coil adjustable tuning cores and trimmer capacitors used to align the receiver, and the adjustment controls on the rear apron, maintain their alignment and adjustment settings for long periods of time. Through the use of various types of springs, all the receiver adjustable fixed and moving parts are provided with positive positioning and operation. Also, flat springs are used on the rotary turret assembly to provide for electrical grounding. The receiver r-f coils, r-f chokes, and all soldered connections are fungicidal varnished for tropicalization; also, all metal parts in contact conform to the electrochemical series of elements so that corrosion is kept to a possible minimum. In view of the fact that all possible precau-

Table 2-1. Special Tools Required for Overhaul

Figure & Index No.	Hammarlund Tool No.	Tool Name	Application
2-1,1	T7982-5	Pin, locating	RF strip assy.
2-1,2	T7982-6	Bar, line-up	
2-1,3	T7982-7	Pin, locating	
2-2,1	T8331-1	Swage	Contact spring and partitions, tuning unit shield.
2-2,2	T8331-2	Mounting, seat	
2-3,1	T7644	Jig, fixture	Turret rotor assy.
2-3,2	T8332	Rod	Turret rotor and tuning unit shield, line-up.
2-3,3	T8333	Wrench, spanner	Turret rotor assy nuts.
2-4,1	T8335	Jig	Band dial location.
2-4,2	T8334	Pliers	"C" washers, crimping.

tions are taken at the factory to provide each receiver for use in perfect condition, the preventive maintenance and overhaul performed on the receiver should

be done with the least possible recourse to the needless unsoldering and replacement of parts.

SECTION II

SPECIAL OVERHAUL TOOLS AND TEST EQUIPMENT

2-1. SPECIAL TOOLS.

2-2. The special overhaul tools required to perform the work outlined in this publication are listed in table 2-1. The table refers to the figure and index number of the illustration for each tool, the tool number, and the tool name. The application column in the table briefly denotes the receiver subassembly or parts to which the respective tools are applied when the re-

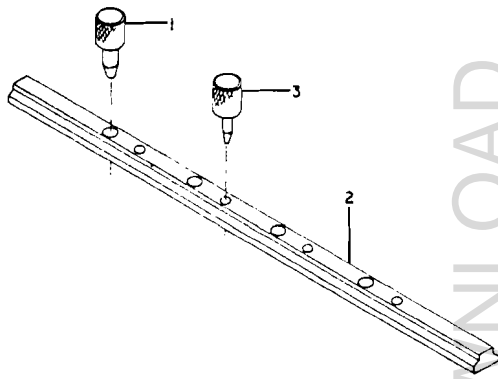

- 1. Large pin
- 2. Line-up bar
- 3. Small pin

Figure 2-1. Special Tools to Reassemble RF Strip Assembly

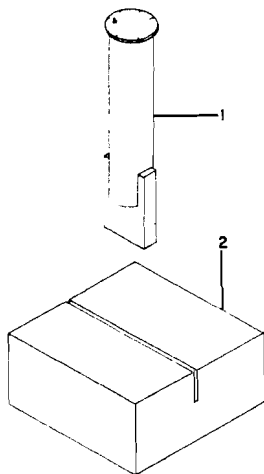

- 1. Swage
- 2. Seat mounting

Figure 2-2. Special Tools to Reassemble Tuning Unit Shield Assembly

ceiver is overhauled. The manner of use and application of each tool is outlined in detail in paragraphs 7-2, 7-3, 8-2.

2-3. SPECIAL TEST EQUIPMENT.

2-4. No special test equipment is required to align, adjust, or final test the radio receiver. To facilitate the testing of the receiver a test position should be maintained, provided with the appropriate test equipment and fabricated cables, as described in the applicable handbook of service instructions.

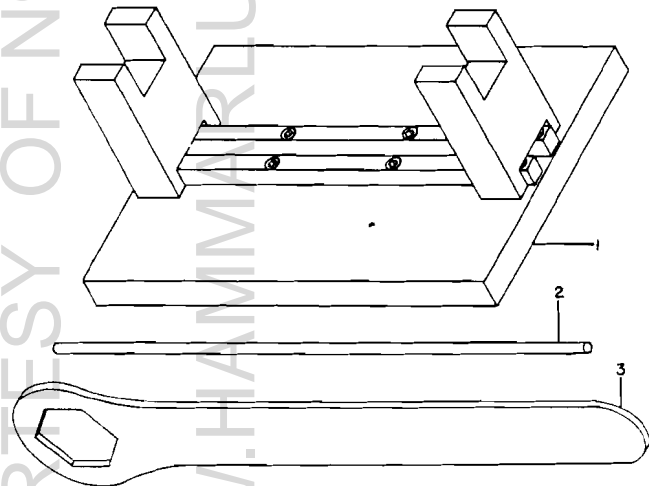

- 1. Fixture jig
- 2. Rod
- 3. Spanner wrench

Figure 2-3. Special Tools to Reassemble Turret Rotor Assembly

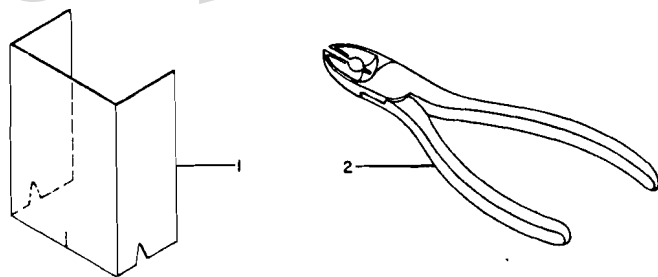

- 1. Jig
- 2. Pliers

Figure 2-4. Special Tools to Reassemble Gear Train Assembly

SECTION III

SPECIALIZED MAINTENANCE AND REPAIR

3-1. GENERAL.

3-2. The specialized maintenance and repair activities within the scope of depot overhaul are based on receiver trouble-shooting data supplementary to that provided in the applicable handbook of service instructions. The data is useful in the step-by-step procedures used to determine specific circuit failures.

3-3. Before specialized maintenance and repair activities are resorted to, ascertain whether the receiver fault is due to any one or more of the following causes:

- a. Damage or miswiring.
- b. Abnormal short circuits between parts or to ground, prior to or subsequent to the reassembly of the subassembly or part to the receiver.
- c. Faulty parts, whose fault is only evident when the part has been allowed to warm up by turning the receiver "on".

3-4. All of the receiver circuitry is accessible, a-part from that contained in the r-f strip. When the receiver fault is isolated to the r-f strip, it must in any case be removed from the receiver for repairs or for replacement. To determine the specific cause of the r-f strip failure requires part by part analysis to the extent required to isolate the faulty part. The r-f strip removed for repairs may be externally reconnected to the receiver through means of insulated "pee-wee" clip leads, to render accessible its circuitry for purposes of analysis. When doing this do not attempt to reconnect the four gang variable tuning condenser unless it too or a spare is external to the receiver. The r-f tuners for the frequency band desired may be seated in the r-f strip steatite base "V" contacts for same.

WARNING

Keep the receiver turned "off" when externally reconnecting the r-f strip to the receiver.

3-5. SPECIALIZED MAINTENANCE OF PARTS.

3-6. The specialized maintenance of parts outlined in each of the following categories differs from that outlined in the applicable handbook of service instructions to the extent that the parts are all analysed with regard to possible failure while contained in the receiver which remains turned "on" and allowed a warm-up period of at least five minutes.

3-7. RESISTOR FAILURE. To determine whether a resistor is normal as evidenced by its resistance value in ohms, determine first its circuit function, noting whether it is isolated or whether it has a d-c voltage drop across it. If the former, determine first, utilizing a volt-ohmmeter, that it has no d-c voltage across it, possibly due to the failure of its as-

sociated isolating capacitor, and then measure its resistance utilizing the volt-ohmmeter. If the latter turn the receiver "off" to measure the resistance of the resistor. To measure the resistance of resistors R32, R33, R60, R61, R66, R68, R93, R94, R95, R96, and R97 unsolder one resistor lead to isolate the resistor from the resistor network of which it is part.

3-8. CAPACITOR FAILURE. To determine whether a capacitor is abnormal to the extent that it is open, shorted, or leaky, i. e. , its construction is at fault in the latter instance such that it has internal series resistance or a conductive shunt path other than normal, determine first its circuit function, noting whether it is used for d-c voltage isolating or filtering purposes, for tuning purposes, or to provide a low impedance series or shunt path for the signal itself.

3-9. OPEN CAPACITOR. An open capacitor cannot provide a low impedance series or shunt path for the signal or be used to tune a circuit to resonance. Also, it cannot provide for filtering action, but will keep a circuit isolated. In the isolating instance the capacitor usually carries the signal or other a-c voltages across it so that an open capacitor can always be analysed with regard to its circuit function. To do this apply an appropriate signal to the applicable test point such that the capacitor under consideration, if normal, may perform its function, and utilize an a-c vacuum tube voltmeter or a cathode ray oscilloscope indication to determine whether the capacitor is open. Each of the following circuit indications, as applicable, provide for checking an open capacitor.

a. When the capacitor is in series with the signal path of the receiver, but open, its input signal indication is much higher than its output signal indication, to ground in each instance.

b. When the capacitor provides a return path to ground for the signal, but is open, its away-from-ground terminal is at an a-c voltage level above ground.

c. When the capacitor is used to tune a circuit to resonance, but is open, the circuit inductance cannot be adjusted for resonance.

d. When the capacitor is used to provide audio filtering action, but is open, its away-from-ground terminal will provide indication of excessive ripple, as compared to when the open capacitor is shunted by a normal capacitor.

e. When the capacitor is used to provide decoupling action in r-f circuits, but is open, more signal indication may be observed, as compared to when the open decoupling capacitor is shunted by a normal capacitor.

3-10. SHORTED CAPACITOR. The effect a shorted capacitor has on the receiver circuitry is such that the shorted capacitor may be rapidly identified. This

is due to the fact that the shorted capacitor cannot have a d-c or a-c voltage drop between its terminals. Each of the following circuit indications, as applicable, provide for checking a shorted capacitor.

a. When the capacitor circuit connection is such that one of its terminals is normally at some d-c voltage above ground, it cannot provide a d-c voltage indication to ground when a volt-ohmmeter or d-c vacuum tube voltmeter is used to make the test.

b. When the capacitor circuit connection is such that only an a-c voltage is normally effective at its terminals, possibly due to the signal, and the capacitor is shorted, no vacuum tube voltmeter or oscillograph indication across the capacitor results. In this instance the signal usually is not evident in the receiver circuitry immediately following the capacitor.

c. When the capacitor is used as a trimmer capacitor, and is shorted, it has no trimmer effect on tuned circuits. In this instance and when the capacitor is used to provide for the parallel resonance of adjustable core tuned circuits, the signal is usually no longer evident in the subsequent receiver circuitry.

d. When the capacitor is shunted by a resistor as is the case in certain of the r-f tuners, and it is suspected that the capacitor is shorted, the shunted resistor, measured for resistance (Refer to paragraph 3-7.), will determine whether the capacitor is shorted. If an indication across the capacitor is to determine whether it is shorted or not, be sure to provide enough signal input to the receiver.

3-11 LEAKY CAPACITOR. In the rare instance when a capacitor is suspected of being leaky such that its leakage characteristics are to be determined, a-

void having to unsolder one of the capacitor terminals from the receiver by utilizing every possible receiver switch and/or tube means to provide for isolating the capacitor terminal. To determine whether a capacitor is leaky do the following:

a. Turn the receiver to its a-c power "off" position.
b. Adjust the volt-ohmmeter to its highest ohmmeter range and connect it across the capacitor. If the capacitor is good the ohmmeter needle flicks over slightly and gradually drops back to infinity.

c. Now reverse the test prods and note that the ohmmeter needle flicks to twice the deflection it did before, the needle then returning to the position indicating infinite resistance, if the capacitor is good. If the needle does not go back to infinite resistance indication the capacitor is leaky and should be replaced. This test is not reliable for capacitors whose capacitance value is less than 0.05 uf.

NOTE

When the capacitor is an electrolytic capacitor one reading will show low resistance and the other much higher. If the higher resistance is not over 100,000 ohms and comparable to that of a prototype capacitor, the electrolytic capacitor must be replaced.

Make sure to turn the receiver "on" at least 15 minutes before making the test to render assurance that the electrolytic capacitor dielectric film deterioration due to shelf life, if any, may be repaired due to subjecting the capacitor to its d-c working voltage.

SECTION IV

DISMANTLING AND DISASSEMBLY

4-1. PRELIMINARY PROCEDURE.

a. Remove the cartoned radio receiver from its wooden shipping box and then unpack it completely.

b. Dismantle the radio receiver top cover and bottom plate, from the receiver chassis and panel assembly.

c. Dismantle the electron tube complement, the front panel controls, the frequency control unit switch arm and eccentric drive assembly, the front panel assembly, etc., from the receiver chassis and panel assembly.

d. Strip the receiver chassis and tuning unit assembly with regard to main dial indicator and mounting, both main and vernier dials, both side plates, etc.

4-2. DISMANTLING OF TUNING UNIT ASSEMBLY.

To dismantle the tuning unit assembly from the receiver chassis and tuning unit assembly, use the following step procedure:

a. Unsolder two green/white leads, one each from the E14 and E17 terminal strips.

b. Unsolder two blue/black leads from the T2 second

mixer transformer.

c. Unsolder white/black, red/white, blue/red, yellow/black, and red/green leads from the E13 terminal strip.

d. Unsolder two red/green, one green/red, and one yellow/red leads of the main wiring cable from the S4 conversion switch.

e. Remove two No. 10-32 screws and one stud post assembly, on either side of tuning unit assembly, which screw into nut plate brackets through clearance holes in gear-train plate and chassis proper.

f. Remove one No. 10-32 screw in angle bracket on rear of tuning unit assembly which passes through clearance hole at back of chassis proper.

g. Lift out the tuning unit assembly.

4-3. The tuning unit assembly comprises several subassemblies which may be dismantled from it and then separately disassembled. These are the following:

a. The mixer plate coil assembly, T1.

b. The r-f wiring assembly, i. e., the r-f strip.

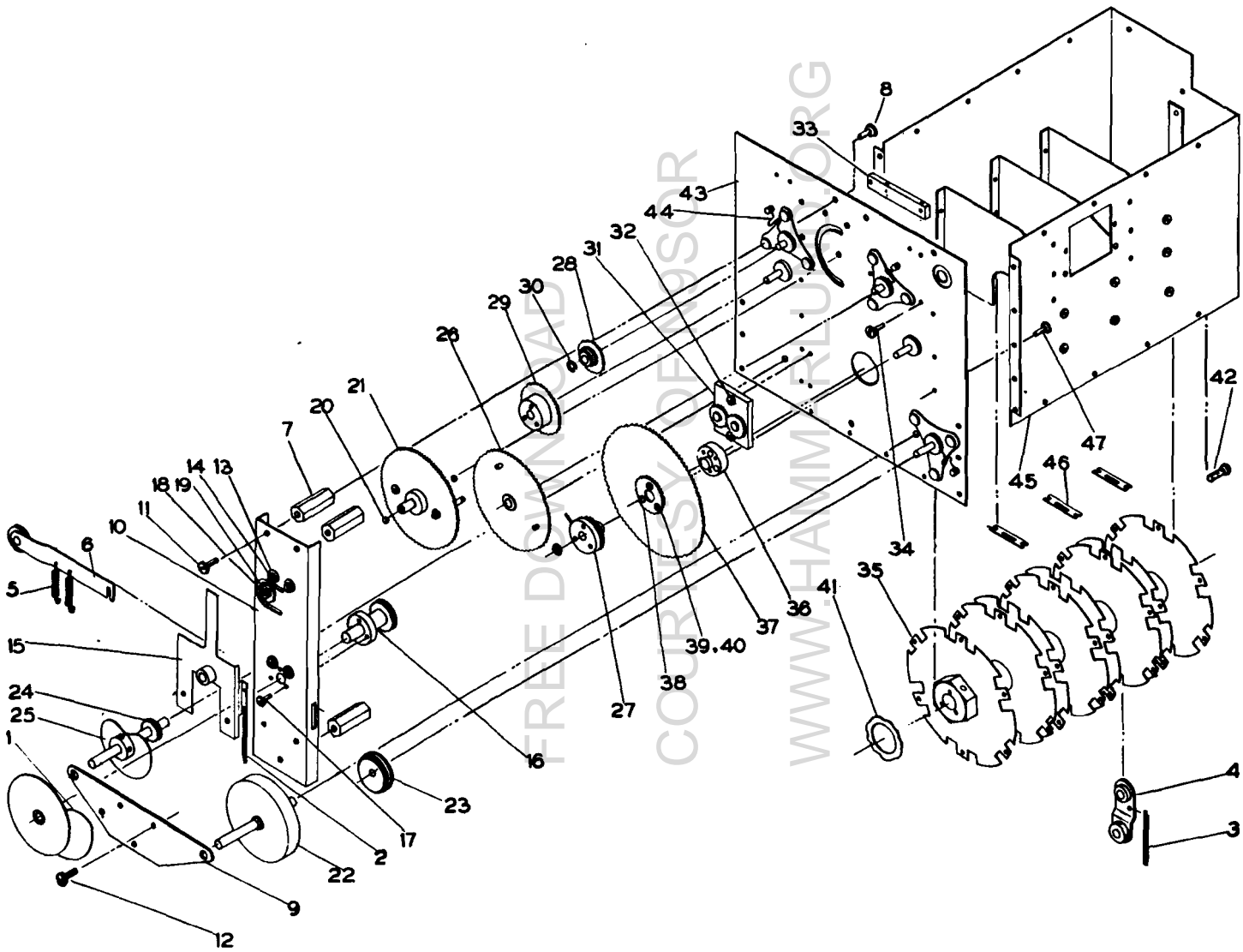

Figure 4-1. Gear Train Assembly, Exploded View

- c. The variable capacitor, i.e., the eight section, four-gang tuning capacitor.
- d. The gear-train assembly.
- e. The 24 r-f coil assemblies, i.e., the r-f tuners.

4-4. **DISASSEMBLY OF GEAR TRAIN ASSEMBLY.** The gear-train assembly (See figure 4-1.), is disassembled in accordance with the following step-by-step procedure.

- a. Remove cam, hub, and band change dial assembly (1).
- b. Remove indicator slide helical spring (2) and conversion switch helical spring (3).
- c. Remove conversion switch lever assembly (4).
- d. Remove the two band change helical springs (5), and then remove the band change cam detent roller and lever assembly (6).
- e. Remove the three No. 10-32 screws (8) used to mount the three mounting posts (7), to which are attached the bearing plate (9) and the bearing plate (10), Doing this provides for the dismantling of the movable support main pointer bracket (15), the shaft, gear, and hub assembly (16), the cam (25) which activates roller and arm assembly, the ball bearings (20), the flywheel (22), the idler wheel (23), and the gear and drive pin assembly (21).
- f. Remove the two spur type gear assembly (26) from the spider assembly at the top right side of the base plate assembly (43), and then remove the spur type gear (27), with included stop pin.
- g. Remove spur type gear (28) from top left side of the base plate assembly (43) and the main dial hub spur type gear (29) adjacent to it.
- h. Remove gear assembly (31), which includes two spur gears mounted on a small brass plate.
- i. Remove the spur type gear (38) and the spur type gear (37).
- j. Remove the rotor assembly front bearing hub (36) and the machine screw (42) at the rear from the rotor assembly, and lift out the mounting disc and shaft assembly (35).
- k. Disconnect the base plate (43) from the tuning unit shield assembly (45).

4-5. **CHASSIS DISASSEMBLY.** The chassis assembly may be disassembled in any sequence desired subsequent to the removal of the three section, four pole, 20-position rotary selectivity switch assembly which is removed first to get at all chassis wiring underneath it. This switch assembly comprises the S5A,

B, C rotary switch, three resistors, five insulated electrical wires, eight bare electrical wires, and two pieces of vinylite tubing which cover in part two of the bare electrical wires. The switch assembly is removed in preference to removing the rotary switch proper to facilitate the unsoldering necessary during removal.

4-6. Certain other subassemblies and parts of the chassis assembly, likewise, are unsoldered in a manner to facilitate the unsoldering necessary during removal. These are:

- a. The bfo injection potentiometer which is removed with all the electrical wire leads that are soldered to it.
- b. The audio output transformer which is removed with all the electrical wire leads and one capacitor that are soldered to it.
- c. The antenna input socket which is removed with two black electrical wires that are soldered to it.
- d. Both the large octal sockets which are removed with the electrical wire leads, resistors, and capacitors that are soldered to them.
- e. The meter a-f adjustment potentiometer is removed with the electrical wire jumper and resistor that are soldered to it.

4-7. The r-f strip, i.e., the r-f wiring assembly, which is contained in the tuning unit assembly, has its tube sockets removed with the bare electrical wires that are soldered to certain of the tube sockets. Also, the isolantite switch bases of the r-f strip are removed with the bare electrical wires, certain resistors, and certain capacitors soldered to them, which do not interfere with the removal.

4-8. The frequency control unit and the audio filter assembly, which are contained in the chassis and panel assembly of the receiver, may be dismantled from the receiver at any stage in the overall disassembly procedure outlined. The frequency control unit octal socket and selector switch are disassembled by unsoldering the bare electrical wire leads soldered to them away from the socket and switch contact terminals; also, having disassembled the octal socket, the bare electrical wire common to the six crystal sockets is unsoldered subsequent to the removal of the crystal socket plate carrying the crystal sockets. The audio filter assembly is disassembled subsequent to its dismantling as a unit.

SECTION V

CLEANING

5-1. OVERALL.

5-2. The radio receiver may be blown out with compressed dry filtered air at a pressure of approximately 100 lb/sq in. Accessible parts may be wiped with a clean cloth. Not too readily accessible parts may be dusted with a small dry brush.

5-3. ELECTRICAL PARTS.

5-4. When the radio receiver is dismantled and its subassemblies are disassembled all wired electrical parts may be blown out, wiped, and dusted as outlined above (Refer to paragraph 5-2.), for the overall receiver. The air pressure at the subassembly or part may be decreased by increasing the distance between the air nozzle and the work.

WARNING

Wear goggles to protect eyes from dust.

5-5. MECHANICAL PARTS.

5-6. All mechanical parts such as the chassis, side plates, shields, screws, etc., may be cleaned by brushing with Federal Spec. VV-K-211b Kerosene or Federal Spec. O-C-141 Carbon-Tetrachloride. To remove corrosion use No. 000 sandpaper as well, then wipe with a clean cloth.

5-7. Dirty gears are cleaned best with a pipe cleaner or small brush dipped in any one of the cleaning fluids mentioned (Refer to paragraph 5-6.). The variable air trimmer capacitors may be cleaned by soaking them bodily in any one of the cleaning fluids (Refer to paragraph 5-6.), and then blowing them out. This applies to the r-f trimmer capacitors even when assembled to their isolantite bases, with r-f coils, resistors, and all other fixed capacitors removed.

5-8. PRESERVATION AFTER CLEANING.

5-9. RF COILS AND CHOKES. The r-f coils and chokes used in the radio receiver are all treated by dipping in bakelite resin, fungicidal varnish approved as per JAN Spec. JAN-C-173. The approved thinner used with this varnish is as per Federal Spec. PTX-916 Grade B.

5-10. FOUR GANG VARIABLE AIR CONDENSER. The four-gang variable air condenser end bearings are lubricated at the factory with Air Force-Navy Aeronautical Spec. AN-G-15a Grease. It may be lubricated in the remote instance when the need arises.

5-11. AIR TRIMMER CAPACITORS. The variable air trimmer capacitors are all lubricated at the factory with Air Force-Navy Aeronautical Spec. AN-G-15a Grease.

NOTE

Do not lubricate the variable air trimmer capacitors even though cleaned as outlined above (Refer to paragraph 5-7.).

5-12. GEAR TRAIN ASSEMBLY. The reassembly of the radio receiver gear-train assembly, (Refer to paragraph 8-2.), subsequent to overhaul, requires that the Military Spec. MIL-G-3278 Grease, used at the factory for lubrication purposes, be replaced. The MIL-G-3278 Grease is applied to the front bearing hub (See 36, figure 4-1.), to the rear bearing machine screw (42), to the two ball bearings (20), to the five tempered shafts on the base plate assembly (43), to the shaft of the flywheel (22), to the shaft of the gear assembly (16), and to the shaft of the gear assembly (24).

SECTION VI

INSPECTION

6-1. GENERAL.

6-2. The radio receiver is inspected, by careful observation and feel, with regard to any possible physical indication other than normal. Even though the receiver mechanical defect appears trivial it must be repaired at the first opportunity presented so that it does not tend to develop cumulative receiver abnormalities leading to serious failure. As such, inspection is closely concerned with preventive maintenance whereby periodic receiver overhaul provides for qualified inspection personnel to determine the need for the immediate repair of the receiver; or, to decide that the nature of the receiver abnormality is insignificant enough to be taken care of at a later overhaul date.

6-3. INSPECTION TECHNIQUE. To provide for the proper inspection of each radio receiver, the inspector must thoroughly familiarize himself with the receiver with regard to each of the following considerations.

a. Determine first the normal appearance of the radio receiver by carefully noting the appearance of each subassembly and part and their assembled inter-relationship (Refer to paragraphs 4-1 thru 4-8 and 8-1 thru 8-3.). Until such time that the normal detailed appearance of the receiver is committed to memory compare the receiver part by part with a receiver known to be in the condition in which it left the factory. Carefully observe the color and finish of all parts, their relative placement, the dressing of each electrical wire, the quality of the crimping of each soldered wire, the amount of solder used to make a soldered joint, and the manner and location of those soldered joints providing for electrical ground. Note that all soldered joints, all r-f coil assemblies, and all r-f chokes are tropicalized as evidenced by their brownish fungicidal varnish coating. Note that the eight nuts at the two escutcheons on the front panel, the 12 nuts at the six crystal sockets on the frequency control unit, the bearing set screw (See 18, figure 4-1.), and each nut used to mount each pin on each of the 24 r-f tuner coil assemblies, is coated with U.S. Army Spec. 3-182 Clear Varnish. The varnish is used as an aid to secure each nut in each instance since not too much strain can be used to tighten each assembly.

b. Determine next the manner in which the receiver operating controls activate the mechanical means used to perform each control function. Get the feel of each control and commit it to memory. Note that the tuning control is flywheel balanced and that it is free to turn even when the tuning lock is locked. Note that the two indicators for the main dial and the one indicator for the vernier dial all simultaneously indicate zero dial indications when the four gang variable air condenser is fully meshed. Note that the movable main dial frequency indicator pointer locates at the

frequency scale on the main dial corresponding to the frequency band indented and whose frequency range is that shown on the dial visible through the small window contained in the front panel. Note the manner in which the frequency control unit crystal switch arm and eccentric drive assembly drives the two switches coupled to the drive assembly, the orientation of the drive arm and the effect of the small helical spring used. Note the spring-return action of the meter switch. Note the extent to which the gears on the gear assembly (See 31, figure 4-1.), mesh with those they engage and the hole provision in the bearing plate (9) to get at one of the screws (32). Note that the lubrication used on the gear-train assembly is barely visible. Note by feel the tightness of the adjustable tuning cores and trimmer capacitors, but make sure not to disturb their adjustment settings.

6-4. RECEIVER ABNORMALITIES. Inspect the receiver with regard to each of the following possible categories of abnormality:

a. AGING. The aging of the receiver is indicated by the sloppy or non-positive operation of movable parts whose normal function during movement or when indented is controlled through the use of springs, cams, gears, ball bearings, or precise bearing fits to trued machined shafting.

b. BURNING. The overheating of the receiver is indicated when parts comprising it show discoloration, blistering, bulging, or smell burnt.

c. LEAKAGE. The evidence of oil or insulating compound at the terminals of sealed container parts provide the earliest possible evidence of receiver leakage. The leakage may be evident too at pin holes and/or breaks in the container enclosed part itself.

d. CORROSION. The evidence of receiver corrosion is the oxidation (rust) which forms on surfaces, screws, nuts, etc., usually where different metal areas are in contact.

e. DUST, DIRT, ETC. The need for cleaning the receiver is evaluated best by the extent to which dust, dirt, etc., has accumulated at electron tube socket terminals, resistor boards, and other not too easily accessible soldered joints and corners in the receiver.

f. LOOSENESS. The need for tightening any subassembly or part comprising the receiver is evaluated by feeling the suspected loose part for tightness. In the instance of attaching hardware such as nuts and/or screws, consider the assembly tight when no more than a 90 degree turn may be taken up in the attaching part. Make sure to reseat those nuts listed above (Refer to paragraph 6-3.), whenever occasion arises to tighten any one of them.

6-5. RECEIVER INSPECTION.

6-6. Apart from the careful inspection of the radio receiver for physical damage evident by observation,

the receiver controls should all be tried to render assurance that they function properly. Dependent on the inspection appraisal of the receiver on receipt for overhaul, a decision should be made as to whether or not the receiver should be turned "on" to determine the electrical condition of certain of its functioning parts, before dismantling and disassembly. Whenever the receiver is turned "on" for inspection, it should be stripped so that the receiver chassis and panel assembly may be under observation. Then inspect the receiver for the following conditions:

- a. Check the r-f gain and the audio gain controls for noisy operation; if so, replace them.
- b. Switch the selectivity switch from position to position and note if the receiver fault is such as to cause arcing at any one of the switch contacts. This is a very remote possibility but in any case each switch contact should be inspected for evidence of charring of the bakelite switch wafers; if any, replace the switch.
- c. Check at all tube socket terminals for possible arcing and charring between terminals; if any, replace the tube socket concerned. To look at the tube sockets on the r-f strip, remove the r-f coil assemblies, and use a small dental mirror.
- d. Check the conversion switch contacts for arcing and evidence of charring between contacts; if any, replace the switch.

6-7. SWITCH, BASE AND SPRING ASSEMBLY. With the receiver turned "off", remove the 20 r-f tuner coil assemblies on five of the six receiver frequency bands, doing this with the receiver chassis and panel assembly turned upside down. Engage the pin contacts of the four r-f tuner coil assemblies kept in the tuning unit assembly with the "V" switch contacts assembled to the isolantite bases contained in the r-f strip, using the band change control on the front panel. Note to see that the "V" switch contacts are spread by the pin contacts and that the pin contacts center up in the "V" switch contacts; also check to see that none of the "V" switch contacts are broken, or that the pin contacts in any one of the 24 r-f tuner coil assemblies are loose. Replace any broken "V" switch contacts and tighten any loose pin contacts, if any.

6-8. SUBASSEMBLY INSPECTION.

6-9. For purposes of receiver overhaul, each subassembly removed from the receiver may be inspected with regard to each of the following considerations, as applicable.

- a. Check the dressing of each part, such as capacitors, resistors, coils, chokes, terminal boards, and the electrical wire lead lengths used. Check the clearance between parts and their mountings, the encoded values and tolerances with regard to resistors and capacitors; also check the part numbers of coils, r-f tuner coil assemblies, and the reference symbol circuit designations on transformer shield assemblies, etc.
- b. Check the quality of each soldered joint and the location and manner of making each specific subassembly ground connection.
- c. Check the tightness of staked terminals, screws, nuts, clamps, and all parts comprising the subas-

sembly. Check each spring for resilience and proper length, curvature, etc. Check adjustable tuning cores for proper operation and if bent, noting the extent to which the tuning core in each instance enters the coil it tunes so that it may be so readjusted prior to reassembly, thereby not necessitating to much of an adjustment during the subsequent alignment.

d. Shake out from the subassembly loose metal and other particles. Make sure none remain wedged in the assembly. Also look closely for metal or other whiskers, if any, especially as between the stator and rotor plates of the variable air trimmer capacitors. Mesh all trimmer capacitors, checking for even meshing and spacing between plates.

e. Carefully check bakelite and melamine boards for scratches and cracks; make sure isolantite bases, insulator feed throughs, and crystal porcelain holders are not minutely cracked or chipped.

f. Check multiple coil assemblies mounted on the same form for spacing. Make sure the start and finish leads on all coil assemblies are properly connected. Check each coil for continuity and for broken strands, (one broken strand is permissible). Check for nicks or scratches on coils and chokes, also check to see that the fungicidal varnish coating provided is not punctured.

g. Check the possibility of the parts of the subassembly shorting to other subassemblies or to the receiver chassis, when assembled. Make sure the pilot lamps, meter board, etc., mount rigidly.

h. Check to see that the metal finish on each of the plated parts contained in the subassembly has the proper finish. Check to see that any excessive fraying of the insulation of electrical wires is cut off and touched up with U.S. Army Spec. 3-182 Clear Varnish.

6-10. PARTS INSPECTION.

6-11. For purposes of receiver overhaul, each part contained in the receiver, when removed, may be inspected with regard to the considerations outlined for it in one of following classifications. When a part fails to meet any one of the considerations listed for it, reject it, but in instances where the part only requires cleaning have it cleaned prior to reinspection. All repaired parts must be reinspected prior to use.

6-12. ELECTRON TUBE INSPECTION.

WARNING

Allow tube envelopes to cool off before handling to avoid severe burns, unless hands are protected.

To inspect each of the electron tubes comprising the 20-tube complement of the receiver, remove the tube shield, if any, and in the instance of three of the tubes unclamp the tube clamp retainer associated with each.

a. Check the firmness of each tube in its socket. Press the tube into the socket, exerting non other than normal pressure. When the tube is properly seated it should be held firmly in place, as evidenced by feel.

b. Let the tubes cool off before removing them from

their sockets in the receiver. Use the appropriate tube remover to remove miniature tubes; also, straighten the miniature tube pins in the appropriate pin straightener before trying to insert the miniature tube into its socket. When inserting the miniature tube do so with the top of the tube socket visible so that the tube pins may be properly aligned in relation to the socket.

c. Inspect the glass or metal envelope of each tube for dirt or corrosion, as applicable; also check to see that the tube envelope is not loose. Make sure that miniature tube pins are not loose or broken, being careful not to bend the pins during removal or insertion of the miniature tube. Check to see that the glass envelope is not chipped at the pins.

6-13. RESISTOR INSPECTION. Apart from the vitreous-enameled bleeder resistor R85 in the B-rectifier supply, which is of the usual lug type and rated at 12 watts, all the resistors in the receiver are of the pigtail, fixed composition insulated type, rated at 1/2, 1/3, or one watt.

a. Inspect the coating of R85 for signs of cracking and chipping, especially at its ends.

b. Examine the body of each resistor for blistering, discoloration, and breaks, due to possible overheating.

c. Inspect all resistor leads for dirt, dust, corrosion, and looseness. Check the security of all mountings. Once a resistor of the pigtail type is unsoldered, do not reuse in instances where leads were initially cut short since the point of entry of the lead may be partially or completely broken, apart from the fact that resoldering may damage the resistor.

6-14. CAPACITOR INSPECTION. The radio receiver capacitor complement comprises various capacitor types. The four gang eight section main tuning capacitor, the 24 r-f tuner coil assembly trimmer capacitors, the delta frequency control capacitor, and the crystal phasing capacitor are all of the variable air type. For purposes of inspection, the temperature compensating, the silver mica molded, the paper molded, and the oil filled paper tubular capacitors are all classified as of the pigtail lead type, while the hermetically sealed, dry electrolytic tubular and bathtub, and paper bathtub capacitors are classified as of the terminal type.

6-15. VARIABLE AIR TYPE.

a. Inspect the capacitor for dust, dirt, lint, and poor or broken soldering.

b. Inspect the capacitor plates for visible damage such as nicks and bending; also, by meshing the rotor and stator plates, making sure that during meshing the plates do not touch and that they remain reasonably centered at all times with regard to plate spacing.

CAUTION

Never tamper with the plates of the main tuning gang condenser.

c. Inspect the capacitor plate mountings, terminals, and overall with regard to looseness, wear, breaks, or other damage, making sure that the main capacitor ball bearings and the trimmer capacitor rotor

spring assembly in each instance provide for smooth firm rotor and stator meshing.

6-16. PIGTAIL LEAD TYPE.

a. Inspect each pigtail type lead capacitor for lead looseness. Do this by applying a firm steady pull to each capacitor lead in turn, making sure that the tension applied is not excessive.

b. Inspect each capacitor for discoloration, breaks, chipping, and evidence that the capacitor molded encasing does not completely enclose the capacitor assembly.

c. Inspect the two oil filled tubular metal case capacitors for evidence of oil leakage at the pigtail lead solder terminal connections, for the quality of the solder terminals, and for corrosion.

6-17. TERMINAL TYPE.

a. Inspect the capacitor terminals for insulation cracks, looseness, corrosion, and evidence of leakage of electrolyte with regard to the dry electrolytic capacitors which may arise when the unit overheats.

b. Inspect the metal case container of each unit for bulges, dents, cracks, and other damage of any kind. Make sure the terminal lugs on the three section electrolytic capacitor are not loose.

6-18. FUSE INSPECTION. The fuse complement of the radio receiver comprises two three ampere holder type fuses, of which one is a spare, and one three-eighths ampere pigtail type fuse. Throw blown fuses away.

a. Inspect the pigtail type fuse for loose leads and both types for loose ends and cracks or breaks in their glass encasings.

b. Inspect the fuse holder and holder cap for evidence of burning, charring, corrosion, and dirt; make sure the spring tension in the fuse holder is strong enough to butt the fuse up against the back of the fuse cap, noting that the cap spring tension only provides for holding the fuse to the cap for insertion or removal.

6-19. INSULATOR INSPECTION. The three insulators used in the radio receiver are of the feed-thru type. That at the power cable is made of black nylon and acts as a strain insulator. That on the frequency control unit is made of steatite and has a white glazed finish while that on the r-f strip is made of white isolantite.

a. Inspect the steatite and isolantite insulators for the possible deposit of foreign matter since an insulator is only as good as the condition of its surface.

b. Inspect the steatite and isolantite insulators for fine-line surface cracks where moisture and dust will accumulate and form a leakage path. Make sure these insulators are clean, without cracks, or chipped in any way and that the quality of the soldering and spinning used for mounting is good.

c. Inspect the nylon insulator to make sure that its physical condition enables it to provide for its strain function.

6-20. SWITCH INSPECTION. The switch complement of the radio receiver comprises 11 switches of which seven are enclosed and four are open to view.

a. Inspect the mechanical action of each switch and

look for dirt, dust, and corrosion on all exposed parts. In the instance of enclosed switches check the switch action of the switch by flipping the control knob or toggle; in the instance of the spring return meter switch, note the amount of pressure needed to overcome the spring tension; in the instance of the crystal selector switch make sure the detent action is positive acting and that the front panel control knob activates the frequency control switch contained in the frequency control unit in each of its seven positions but only activates the switch S3 on the base plate (See 43, figure 4-1.), in its most counter-clockwise position.

b. Inspect the switch base and spring assembly (Refer to paragraph 6-6.), and the three section selectivity switch contacts for looseness, dust, dirt, and corrosion, making sure that the rotors of each switch make contact with the stators as evidenced by the visible spreading of the stators when engaged by the rotors. Do not pry the leaves of the stator contacts apart in any manner whatsoever, other than by the engagement of the switch rotors themselves.

6-21. RF COIL AND CHOKE INSPECTION. Apart from the r-f coil contained in each of the 24 r-f tuner coil assemblies, the radio receiver has an i-f output autotransformer coil, eight r-f chokes, and 15 r-f coils, the latter contained in the various transformer subassemblies comprising the receiver. Four of the 15 r-f coils, contained in the second and driver i-f transformers, are each further contained in two iron cups for purposes of shielding. No attempt should be made to remove said iron cups, the coil assembly itself is to be replaced whenever the need for the replacement of these r-f coils arises.

a. Inspect each r-f coil, r-f choke, and shielded r-f coil for cleanliness, the quality of soldering, the firmness of the terminals and the assembly, fungicidal varnishing, no loose coil turns, as applicable. Make sure that there are no nicks or cracks in the coil forms or in the fungicidal varnish coatings provided each coil. Remember that the coil form functions as a high-voltage insulator whose requirement is the utmost in cleanliness.

b. Inspect each r-f coil and r-f choke for the continuity of each winding. Check the d-c resistance of each winding by comparison with the d-c resistance values of the appropriate new r-f coil or r-f choke, remembering to make allowance for one broken strand in the instance of r-f coils wound with litz wire. Note that the secondaries of the three r-f coils in the r-f tuner coil assemblies used on the 1.35-3.45 mc frequency band of the receiver and the four iron cup shielded i-f coils each use No. 15/44 litz wire. In all other applicable instances No. 7/41 litz wire is used.

6-22. POTENTIOMETERS. The radio receiver utilizes potentiometers as r-f gain, audio gain, a-f meter adjustment, r-f meter adjustment, and bfo injection controls.

a. Inspect the metallic parts of each control for dust, dirt and evidence of corrosion. Make sure that the unit has no mechanical defects such as loose terminal lugs, loose body assembly, and a loosely keyed shaft.

b. Inspect the insulated body of the unit for cracks,

and chipping.

c. Inspect the operation of the control making sure that the shaft turns smoothly but firmly in its mounting.

6-23. TERMINAL BOARDS. The radio receiver utilizes 15 terminal boards for purposes of part mounting.

a. Inspect the mechanical assembly of each terminal board with regard to loose brackets, terminals, eyelets, rivets, etc.

b. Inspect the terminal board melamine insulation for cracks, breaks, dirt, possible charring, or possible breakdown of the insulation due to the corrosion of the metal parts of the terminal board assembly.

6-24. CORDS AND CABLES. The main wiring cable, the a-c power cord, and one three-inch shielded insulated lead cable comprise the cord and cable complement of the receiver. The main wiring cable is pre-fabricated before assembly to the receiver chassis and comprises, apart from numerous electrical wires, four shielded insulated lead cables.

a. Inspect the insulation of the a-c power cord, of each visible electrical wire and cable contained in the main wiring cable, and that of the three-inch shielded lead cable, noting whether the insulation is cracked, deteriorated, cut, kinked due to improper support, or strained due to improper placement.

b. Inspect the cord and cables at each end of each lead for broken strands, fraying of the insulation, and damage due to poor soldering and crimping. A few broken strands are not serious but make sure that many partially or completely broken strands are not hidden by the insulation.

c. Inspect to see that the braided shield of the five shielded insulated lead cables does not short to the cable lead wires.

6-25. CONNECTORS AND SOCKETS. The antenna input and the i-f output connectors, the phone jack, the power and the relay receptacles, the six crystal and 20 electron tube sockets, comprise the connector and socket complement of the receiver.

a. Inspect the insulation of each for dirt, dust, corrosion, charring, and cracks.

b. Inspect contacts for collected dust, corrosion, breaks, and other than normal looseness.

c. Inspect each connector and socket with regard to the contact provided when its complementary plug, crystal, or tube is inserted. Increase, when needed the spring tension of the phone jack. When a tube socket has replaceable contacts and requires replacement, this may prove more practical than replacing the tube socket.

6-26. METER. The tuning meter contained on the front panel of the receiver has a 100 ma d-c movement and is provided with two scales.

a. Inspect the meter for cracked or broken cover glass, dents in the case, a warped dial, and bent or broken pointer.

b. Inspect the meter for dust, dirt, and corrosion on the meter case and terminals. Remove the meter cover and repeat the inspection for the inside of the meter cover and the meter proper.

c. Inspect, by checking the meter adjustment screw,

to see that the pointer may be properly set to the initial dial indication from either direction. Make sure that the adjustment spring is not caught on the adjustment arm.

d. Test the meter for balance by incorporating it in a circuit such that it will indicate +20 db on the r-f scale at 100 ua plus or minus five percent, and will repeat this test.

6-27. CRYSTALS. The 3.5 mc oscillator crystal and the 455 kc i-f filter crystal, apart from any specially ordered crystals used for fixed frequency crystal controlled operation, comprise the crystal complement of the receiver.

a. Inspect each crystal for dust, dirt, cracks, breaks, and corrosion.

b. Inspect the 455 kc crystal terminals, to which are soldered pigtail type leads, and the 3.5 mc osc crystal flat strip terminals, to make sure that they are tight, also inspecting the quality of the pigtail lead soldering in the instance of the former and the terminal silver plating of both. Make sure that the cover spring retainer for the 3.5 mc osc crystal provides sufficient tension to firmly seat itself.

c. Inspect the separately ordered crystals for dust, dirt, dents, poor soldering of metal case, corrosion of case and pin terminals, cracked terminal pin insulation, and loose terminal pins. These crystals are ordered according to Military Spec. MIL-C-3098, are of the Type CR-18/U, but have metal stamped on the top and one face side the signal frequency in kc for which they are intended.

6-28. TRANSFORMERS AND CHOKES. The receiver audio output and power transformers and the two B-rectifier filter chokes are all of similar container construction. The power transformer is oil impregnated and hermetically sealed. The audio transformer is oil filled. The two filter chokes are hermetically sealed.

a. Inspect for blistering, bulging, or leakage from containers and from terminals.

b. Inspect for broken, cracked, or charred insulation at the terminals. Inspect to make sure terminals are not loose.

c. Inspect for dust, dirt, lint, or foreign material between terminals since same will absorb moisture which in time provides a leakage path for high voltage breakdown between terminals.

6-29. FUNCTIONAL MECHANICAL PARTS. The mechanical parts such as coupling shafts, couplings, drive arm and eccentrics, gears, lever and roller, dials, cams, control knob and dial assemblies, springs, etc., which provide for the proper mechanical functioning of the receiver, all require inspection.

a. Inspect for dust, dirt, and corrosion.

b. Inspect for damage, such as cracks, distortion, poor etching, etc as applicable.

6-30. MECHANICAL PERFORMANCE STANDARDS. The mechanical performance standards of the radio receiver when subjected to normal use are most easily evaluated in terms of the minimum (electrical) performance standards of the receiver; normal use implying that the receiver is not subjected to extreme vibration, extremes in temperature and/or

humidity, or exposed to dust, dirt, etc. When the receiver is subjected to abnormal use, or is dropped an evaluation of the abnormalities or damage sustained determine the extent to which the receiver certain of its subassemblies, or parts require overhaul.

6-31. LIFE OF THE RECEIVER. The life of the receiver is directly dependent on the preventive maintenance performed with regard to maintaining the receiver in its normal mechanical and electrical state. The replacement of functional mechanical and/or electrical parts, subassemblies, etc., will not impair the subsequent life of the receiver.

6-32. SERVICE LIMITS. The normal mechanical requirements of the receiver provide for no allowable service limits with regard to the mechanical functioning of the receiver parts and subassemblies comprising it. The improper mechanical functioning of the receiver, after long periods of normal use, may be directly attributable to any one or more of the following conditions.

a. Due to accumulations of dust, dirt, sediment, moisture and the resultant corrosion, rotting, etc. the mechanical functioning parts of the receiver may become clogged and subsequently worn so that they no longer function normally.

b. Due to repeated use and mechanical fatigue, the attaching hardware used to assemble the parts and subassemblies to the receiver may loosen up somewhat such that the receiver mechanical functioning becomes impaired, further use possible resulting in damage to functioning parts.

c. Due to repeated use and mechanical fatigue, the numerous springs used in the receiver may no longer provide the necessary tension required for the normal functioning of the receiver.

d. Due to the repeated use under conditions tending to extremes with regard to vibration, temperature, and humidity, the tendency to other than the normal mechanical functioning of the receiver may be accelerated.

6-33. Whenever the receiver is subjected to overhaul not directly due to the abnormal use of the receiver, the overhaul of the receiver should provide for each of the following checks to be made with regard to the spring complement of the receiver.

a. Check to see that each of the three contact springs used on the partitions in the tuning unit shield assembly are not loose and make positive contact with the turret rotor assembly.

b. Check to see that the wavy washer at the front end of the turret rotor assembly is not loose such that it fails to turn when the turret rotor assembly is indented from one band to the next. A loose wavy washer indicates turret rotor endplay.

c. Check to see that the "U" shaped contact spring at the rear of the turret rotor assembly provides firm wiping contact with the turret rotor assembly and that it is not loosely mounted.

d. Check to see that the receiver helical spring complement, namely that at the pointer slide, the two at the lever and roller detent assembly, and that at the conversion switch, have not lost their tension, doing this by removing each in turn and noting that its

unloaded length is normal, i. e., the same as its unused counterpart.

e. Check to see that the three spider springs at the gear-train assembly are not distorted in any way from their normal unmounted shape by comparing them with their normal unused counterpart.

f. Check to see that the 24 r-f tuner coil assemblies, the 24 r-f coils mounted on them, the six separately

ordered crystals, all adjustable tuning cores, and all trimmer capacitors, are all provided with sufficient mounting tension from their respective mounting springs as evidenced by feel for possible looseness.

g. Check to see that the "V" contact springs on the band change switch base and spring assembly are not broken and that they provide contact with the switch pins on each of the r-f tuner coil assemblies.

SECTION VII

REPAIR AND REPLACEMENT

7-1. GENERAL. The radio receiver comprises parts of which none should be subjected to repair. However, all parts comprising the receiver may be replaced. Of these the replacement of each of the four base and spring assemblies, comprising parts contained on the r-f strip, requires further consideration.

7-2. SWITCH BASE AND SPRING ASSEMBLY. To replace any one of the four base and spring assemblies comprising the stator of the band change switch, first remove the r-f strip from the receiver. The reason for the replacement may be that any one of the six "V" contact springs on each of the four isolantite bases or the bases themselves, may be broken.

a. To replace a "V" contact spring, the defective spring is removed by first removing the solder from the spring terminals which holds the spring in place in the isolantite base. Then spring back the spring ear on each spring leg in turn while pushing in a direction to remove the spring. Note the spring ear locations on the spring to be replaced. A new spring is then substituted for the defective spring removed, solder being used to retain it in place in a manner evident from any of those contained in any one of the isolantite bases.

b. To replace a base and spring assembly use is made of the line-up bar (See 2, figure 2-1.), and pins (1, 3.), to properly locate the base and spring assembly with regard to its inter-relation to the rest of the r-f strip assembly. The terminals of the isolantite base to be replaced are all cleared first by unsoldering the parts and leads soldered between them and the r-f strip proper. The isolantite base itself is then unsoldered by removing the solder from the two eyelets it contains, and through means of which it is mounted to the r-f strip. The isolantite base is then removed so that a new one may be used to replace it. To properly locate the new isolantite base, the line-up bar (2) is located over it and the other isolantite bases contained in the r-f strip. The line-up bar (2) is then located in relation to the isolantite bases soldered to the r-f strip through means of the pins (1, 3) which fit thru the line-up bar holes and into the two

holes in each of the isolantite bases. Pin (1) is used in the smaller and pin (3) in the larger of the two holes in each base. The new isolantite base is then likewise located so that when soldered into place its desired position is up against the line-up bar as are all others. The eight pins and the line-up bar are then removed and the r-f strip parts and leads previously unsoldered, are resoldered to the new isolantite base, all dressed as they were previously by duplicating an r-f strip kept on hand for purpose of a sample.

7-3. SELECTIVITY SWITCH. The selectivity switch which provides three crystal and three non-crystal positions of receiver acceptance band width is a three section wafer type switch assembly which is assembled to the receiver with other parts (Refer to paragraph 4-5.), assembled to it. It is recommended that the switch assembly be replaced as a unit as compared to replacing any one of the wafers comprising it, the reason being that the switch is purchased as a unit, the replacement of a wafer being a complicated procedure due to the fact that its contact construction assembly is peculiar to the receiver.

7-4. RETROPICALIZATION. The soldered joints, r-f coils, and r-f chokes in the radio receiver are all treated with fungicidal varnish to render them moisture- and fungus-resistant.

a. In the instance of coils and chokes, not otherwise damaged, but where the tropicalization requires some touch-up, a small brush dipped in the JAN Spec. JAN-C-173 varnish, thinned down, with approved thinner as per Federal Spec. PTX-916 Grade B, may be used to brush the varnish on the coil or choke, as needed.

b. In the instance of soldered joints, subsequent to resoldering, each joint is treated with the varnish by brushing the varnish to completely cover the soldered joint.

c. In the instance when any soldered joint, even when not a resoldered joint, is found to be poorly treated with the varnish it should be retreated to provide for its complete varnish coverage.

SECTION VIII

REASSEMBLYING AND TESTING OF SUBASSEMBLIES AND ASSEMBLIES

8-1. REASSEMBLY. The reassembly of the radio receiver comprises the separate reassembly of the receiver chassis assembly and the receiver tuning unit assembly. The receiver chassis reassembly need not follow a specific step sequence, other than that the main cable wiring assembly be added first and the selectivity switch assembly (Refer to paragraph 4-5.), be assembled last to the receiver chassis. The frequency control unit and audio filter assemblies (Refer to paragraph 4-6.), may be reassembled to the receiver chassis assembly prior to reassembling the receiver tuning unit and chassis assemblies.

8-2. REASSEMBLY OF TUNING UNIT ASSEMBLY. Before attempting to reassemble the tuning unit assembly, it is recommended that the following step procedure be understood fully so that the various reassembly requirements are anticipated during the actual assembly. The tuning unit assembly comprises several subassemblies (Refer to paragraph 4-3.). Of these the gear-train assembly (See figure 4-1.), consists of a tuning unit shield assembly (45) and a mounting disk and shaft assembly (35) which are reassembled subsequent to the addition of the base plate assembly (43) to the tuning unit shield assembly (45). The gears, parts, etc. which comprise the gear-train are then built up on the base plate assembly (43) to completely reassemble the gear-train assembly.

a. Reassemble the tuning unit shield assembly (See 43, figure 4-1.), noting that one each of the three flat springs (46) are associated with each reinforcing plate of the tuning unit shield assembly (45). The flat spring (46) is seated on the reinforcing plate prior to assembly, the swage tool (See 1, figure 2-2.), and mounting (2) being used to swage the reinforcing plate metal so as to properly seat and firmly retain the spring.

b. Reassemble the tuning unit shield assembly (45) to the base plate (43).

c. Reassemble mounting disk and shaft assembly (35), using the jig fixture (See 1, figure 2-3.), the rod (See 2, figure 2-3.), and the spanner (See 3, figure 2-3.). The rod is used to line up the eight mounting disks by meshing with the locating holes in each so that when the fixture is used to seat the mounting disk and shaft assembly parts, the disk alignment requirements are met prior to tightening the assembly with the spanner.

d. Reassemble the mounting disk and shaft assembly (35) to the tuning unit shield and base plate assembly by locating the curved washer (41) on the large nut at the front end of the mounting disk and shaft assembly (35) and then seating the combination in the tuning unit shield and base plate assembly.

e. Add front bearing hub (36) to front end of the mounting disc and shaft assembly (35) using three No. 8-32 machine screws (40) and three split lock-

washers (39). Also add the machine screw (42), it acting as the rear bearing for same. Make sure the curved washer (41) is centered on large nut at front end of the mounting disk and shaft assembly (35) before tightening the two bearings. Lubricate both bearings using Military Spec. MIL-G-3278 Grease.

f. Use rod (See 2, figure 2-3.), to line up mounting disk and shaft assembly and tuning unit shield and base assembly, through means of the alignment holes in each, so that the conversion switch cam at the rear of the mounting disk and shaft assembly is in its high position when the switch blade of the conversion switch, assembled to the tuning unit shield assembly, shorts its center fixed contact to its fixed contact closest to the edge of the tuning unit shield assembly.

g. Add the two loop type springs (44) to the top of the base plate assembly (43) and add the anchor plate (33) for the r-f strip, using two No. 6-32 machine screws (34), to the base plate (43).

h. Add the large spur type gear (37) and the small spur type gear (38) using three No. 8-32 machine screws (40) and three split lockwashers (39), to the hub (36). Also add the gear assembly (31), using two No. 6-32 machine screws (32), to the bottom left side of the base plate (43), but do not tighten the assembly.

i. Add the three mounting posts (7) using three No. 10-32 machine screws (11).

j. Add the gear assembly (21) by locating it to the ball bearing (20) at the base plate assembly (43) provision for same with Military Spec. MIL-G-3278 Grease, and to the other ball bearing (20), located with grease, at the bearing set screw (18) mounted on the bearing plate (10) by the nut (19); and then holding it in place by mounting the bearing plate (10), carrying the lubricated loosely mounted gear assembly (16), to the two top posts (7) using two No. 10-32 machine screws (11).

k. Lubricate, using Military Spec. MIL-G-3278 Grease, the five tempered shafts on the base plate assembly (43).

l. Locate the drive pin assembled to the gear assembly (21), by turning the latter so that the drive pin is at the top of the slot in the base plate assembly (43). Add the two spur type gear assembly (26) to the spider assembly at the top right of the base plate assembly (43) and mesh with the vernier dial spur type gear (27), added to the adjacent shaft contained on the base plate assembly (43), so that the stop pin of the spur type gear (27) is radial with the center of the two spur type gear assembly (26) and against one of the buttons contained thereon when the spur type gear (27) is turned clockwise. Now back away the gear assembly (21) so that the drive pin contained thereon is one tooth (maximum of two teeth) away from its position at the top of the slot in the base plate assembly (43), and mesh in this position with the two spur type gear assembly (26). Having engaged gears in this manner install "C" washer retainer rings (30), one on each

of the shafts, namely the spider shaft and the shaft adjacent to it. Use the pliers (See 1, figure 2-4.), to tighten the retainer rings.

m. Add the spur type gear (28) to the top left spider on the base plate assembly (43). Also add the main dial hub spur type gear (29) to the shaft adjacent to the spider. With the vernier dial spur type gear (27) so that its stop pin is up against button stop as outlined above (Refer to paragraph 8-2.), the upper tapped hole in the main dial hub spur type gear (29) is located so that a straight edge bisects said tapped hole when the straight edge is butted up against the shafts which carry the main dial hub spur type gear (29) and the spur type gear (28). Add retainer rings (30) one each to the shafts carrying gears (28) and (29).

n. Add idler wheel (23) to the bottom spider on the base plate assembly (43). Lubricate the shaft of fly-wheel (22) and the shaft of gear assembly (24) using Military Spec. MIL-G-3278 Grease, add the cam (25) to the latter and mount all of same with the bearing plate (9), using one No. 10-32 machine screw (11) for the bottom post (7), and two No. 8-32 machine screws (12).

o. Add the band change cam detent roller and lever assembly (6) and the two helical springs (5) for same. Bring cam (25) forward to bearing plate (9) and locate cam in roller, lining up cam with the roller and lever assembly (6), arm, and then tighten the set screws in the cam (25).

p. Check for smooth overall operation and then tighten the two No. 6-32 machine screws (32) which are used to mount the gear assembly (31).

q. Adjust bearing set screw (18) mounted on the bearing plate (10) for no slack but make sure mounting tap is not bent out during the adjustment.

r. Tighten the three machine screws (17) which mount the hub of the gear assembly (16) to the bearing plate (10) so that the gear of the gear assembly (16) meshes properly with the small spur type gear

(38) mounted on the front bearing of the mounting disk and shaft assembly (35).

s. Add the movable support main pointer bracket (15), the four retainer disks (13), mounted by the four No. 4-40 machine screws (14) providing for positioning the movable bracket (15). Also add the indicator slide helical spring (2).

t. Add cam, hub, and band change dial assembly (1), locating dial so that hairline on it lines up with that on the jig used (See 2, figure 2-4.), which is mounted for this purpose over the assembly (1) on the movable bracket (15) and its mounting.

u. Add main and vernier dials, and dial indicator pointers, setting dials to the indicators so that both dials start from zero dial indication. Add main dial pointer to movable bracket (15) with the pointer set to the main dial first frequency mark line.

8-3. RESOLDERING AND RETROPICALIZATION.

The reassembly of the radio receiver requires that all electrical wires which were unsoldered, to dismantle and disassemble the radio receiver, be resoldered. Subsequent to resoldering each soldered joint must be completely covered with fungicidal varnish, approved as per JAN Spec. JAN-C-173, by brushing each joint with a small brush dipped in same. To maintain performance, all electrical wires and part lead lengths, the electrical wires prewired to subassemblies and parts, their dressing and the dressing of all parts, the manner and location of each ground connection, must duplicate in each instance the factory techniques incorporated into each radio receiver.

8-4. TESTING OF SUBASSEMBLIES AND ASSEMBLIES.

The test procedure used with regard to a receiver subassembly is to reassemble the repaired subassembly or a new one to the receiver and then to test the radio receiver as outlined in the applicable Handbook of Service Instructions.

SECTION IX

REASSEMBLY AND TESTING OF COMPONENTS

9-1. REASSEMBLY. The reassembly sequence of the radio receiver is to reassemble the subassemblies comprising it separately and then, in turn, to reassemble the subassemblies into an assembly to which is added the bottom plate and top cover. The subassemblies themselves comprise sub-subassemblies some of which only involve the addition of parts to other parts to facilitate their subsequent subassembly assembly (Refer to paragraph 4-5.).

9-2. REASSEMBLY OF THE CHASSIS AND TUNING UNIT ASSEMBLY. The procedure to reassemble the chassis and tuning unit assembly is to add the tuning unit assembly (Refer to paragraph 8-2.), including the gear-train assembly and the tuning unit shield assembly, to the chassis assembly (Refer to paragraph 8-1.), in the following manner.

a. Seat the tuning unit assembly into the chassis assembly.

b. Fasten the tuning unit assembly at its rear end to the chassis assembly, using a No. 10-32 machine screw with included external-tooth washer, by passing the screw thru the angle bracket on the tuning unit assembly and thru the hole in the chassis assembly, and then adding a No. 10 lockwasher and a No. 10 nut to the No. 10-32 machine screw.

c. Fasten the tuning unit assembly at its front end to the chassis assembly, using two No. 10-32 machine screws with included external-tooth lockwasher, and one stud screwed into a spacer post, at either front side of the tuning unit assembly, by passing the two screws and the stud thru clearance holes in the chassis assembly to screw into two nut plate brackets used.

Table 9-1. Identification of the R-F Tuners

BAND NO.	MC FREQ RANGE	HAMMARLUND PART/DRAWING NO.			
		INPUT	INTERSTAGE		OSCILLATOR
1	0.54-1.35	31387-1	31386-1	31386-1	31385-1
2	1.35-3.45	31390-1	31389-1	31389-1	31388-1
3	3.45-7.40	31393-1	31392-1	31392-1	31391-1
4	7.40-14.80	31396-1	31395-1	31395-1	31394-1
5	14.80-29.70	31399-1	31398-1	31398-1	31397-1
6	29.70-54.00	31405-1	31404-1	31404-1	31403-1

d. Resolder two red/green, one green/red, and one yellow/red lead of the main wiring cable to the S4 conversion switch.

e. Resolder one white/black, one red/white, one blue/red, one yellow/black, and one red/green lead, comprising leads from the terminal board E13 adjacent to the filter assembly, to the top terminal strip of the mixer plate transformer assembly T1 on the tuning unit assembly.

f. Resolder the two blue/black leads of the tuning unit assembly to the T2 second mixer input transformer.

g. Resolder the two green/white leads of the tuning unit assembly, one to the E17 terminal board at the front of the chassis assembly alongside the selectivity switch and the other to the E14 terminal board normal to the former at the front end of the switch.

h. Retropolicalize all soldered joints (Refer to paragraph 7-4.).

9-3. REASSEMBLY OF THE CHASSIS AND PANEL ASSEMBLY. The procedure to reassemble the chassis and panel assembly is to assemble the receiver front panel assembly to the chassis and tuning unit assembly (Refer to paragraph 9-2.), in the following manner.

a. Fasten the front panel assembly to the chassis and tuning unit assembly using eight, one inch No. 10-32 machine screws, four on each side of the front panel, and two, half inch No. 10-32 machine screws at the bottom of the front panel, the latter screwing into the spacer posts used in the reassembly of the tuning unit assembly to the chassis assembly. Each No. 10-32 machine screw has a No. 10 lockwasher added to it.

b. Relocate all toggle switches and the phone jack and fasten each to the front panel using the nut located on the shaft bushing of each, during disassembly.

c. Relocate all four flexible couplings to engage their respective shafts contained in the front panel and tighten the set screws contained in each.

d. Add the r-f gain, tuning, band change, and audio gain knobs to the appropriate control shaft of each and tighten the set screws contained in each.

e. Assemble the small eccentric, the large eccentric, and tie rod, which together provide the drive assembly for the S3 crystal switch located on the base

plate of the gear-train assembly, and add the large eccentric to the extension shaft of the S2 crystal selector switch. Now locate the extension shaft into the fixed coupling at the frequency control unit and through the clearance hole for it in the front panel. Seat the small eccentric on the shaft of the S3 crystal switch and locate the tie rod so that it is normal to the extension shaft. Tighten the set screws in the fixed coupling and those on the small and the large eccentric so that when the crystal selector switch S2 is in its most counter-clockwise position, the crystal switch S3 is also in its most counter-clockwise position. Add the small helical spring to the S3 crystal switch and the knob to the extension shaft at the front panel.

9-4. REASSEMBLY OF THE RADIO RECEIVER. The final step in the reassembly of the radio receiver is to add the bottom plate and then the top cover to the chassis and panel assembly (Refer to paragraph 9-3.), in the following manner.

a. Reassemble the bottom plate using seven No. 10-32 machine screws with included external-tooth lockwashers.

b. Reassemble the top cover including a rubber packing strip, by butting the rubber packed end of the top cover up against the panel of the chassis and panel assembly while tightening the four No. 6-32 machine screws including external-tooth lockwashers, each of which passes thru one of the four mounting brackets which form part of the top cover proper.

9-5. REASSEMBLY OF THE RF TUNERS. The 24 r-f tuners or r-f coil assemblies are subassemblies which are considered part of the tuning unit assembly proper. Even so they may be reassembled to the chassis and tuning unit assembly or to the chassis and panel assembly, preferably to the latter. Each r-f tuner has stamped on its steatite base the Hammarlund part/drawing number applicable to it. Table 9-1 identifies each r-f tuner so that it may be properly reassembled to the chassis and panel assembly of the receiver. For each frequency band the input r-f tuners are reassembled to the rear end of the rotor and mounting disk assembly contained in the tuning unit assembly. Next in reassembly sequence are the two interstage r-f tuners, the oscillator r-f

tuner for each band being reassembled to the rotor and mounting disk assembly nearest to the front panel of the receiver. When making the reassembly the r-f tuners are reassembled to the one of the two most exposed positions of the rotor and mounting disk assembly as viewed from the bottom of the receiver so that when the band change control knob on the front panel is turned clockwise the reassembled r-f tuners move to the other most exposed position of the rotor and mounting disk assembly. The reassembly of the Band No. 4 r-f tuners is made with the band change dial set for Band No. 1 so that when the band change

control knob on the front panel is turned clockwise the r-f tuners for Band Nos. 5, 6, 1, 2, and 3 are reassembled in sequence.

9-6. TESTING. The chassis and panel assembly (Refer to paragraph 9-3.), subsequent to reassembly is aligned and adjusted as per the instructions outlined in the applicable handbook of service instructions. The receiver is then tested with regard to the minimum performance standards specified for it in the applicable handbook of service instructions.

SECTION X FINAL REASSEMBLY

10-1. GENERAL. The reassembly of the radio receiver (Refer to paragraph 9-4.), comprises the final

reassembly of the complete equipment.

SECTION XI INSPECTION AND TESTING

11-1. GENERAL. The radio receiver comprising the complete equipment is aligned, inspected, and tested with regard to the considerations outlined in the applicable handbook of service instructions.

NOTE

Markings of equipments required by Government T.O.'s or other instructions, to indicate overhaul or the incorporation of changes, shall be applied during inspection and test (if not previously applied to subassemblies, assemblies, or components during overhaul and assembly).

11-2. MINIMUM PERFORMANCE AND TEST VAL-

UES. The minimum mechanical performance and electrical test standards applicable to the radio receiver, comprising the complete equipment, are those outlined and specified in the applicable handbook of service instructions. No tolerances are applicable to the mechanical performance of the receiver, while the electrical test standards specified for the receiver may be exceeded but never "opened up" to provide for the acceptance of a specific receiver. The performance of each radio receiver used in an operational activity, comprising other electronic equipment, duplicates that of the receiver as separately inspected and tested to conform to its minimum performance and test values. The adequate shielding incorporated into the receiver design precludes the possibility of receiver radiation to any associated equipment.

