

INSTALLATION INSTRUCTIONS FOR CODE #1
MODIFICATION KIT #9010-14-00001 TO HXL-1
LINEAR AMPLIFIER

INTRODUCTION

This Instruction Sheet contains all the necessary information for installation of Code #1 Modification Kit and changes to the Technical Description and Operating Instruction Manual.

INSTALLATION

- Step 1. Locate terminal strip on bottom of chassis below the Meter. Connect a .1 MFD, 100V disc capacitor, (C129) from lug on terminal strip to ground on terminal strip.
2. Locate the parasitic suppressor assembly on top of the chassis. This assembly connects the plates of V101 and V102, through L101 and R101 to the top of L102. Remove the screw in top of L102 and tube cap clips from the plate caps on V101 and V102. The new parasitic suppressor assembly can be installed by reversing the above procedure. It should be noted that any wax on the corona cap on the top of L102 should be removed for optimum performance.
3. Locate switch S103, adjacent to the base of tube socket for V101. Remove S103 by unsoldering the 4 leads going from the switch to coil (L105A). Unsolder the 4 leads on the end connected to L105A. Disconnect C112 and R104 located between terminal strip and S103 by unsoldering at the switch. Loosen Allen screws in shaft coupling, securing shaft of switch to shaft extension. Remove pal nut holding switch to bracket, remove switch from unit. Remove bracket by removing the two (2) screws holding the bracket in place. Remove extension shaft and coupling by loosening the Allen screw in dial cord drum. Place temporary shaft in dial cord drum to hold drum and nylon bushing in place while switch extension shaft is being modified. Cut switch extension shaft 3 1/8" overall length and replace in original position.
4. Place flat washer first and then shoulder washer on switch shaft. (Shoulder washer must be centered with hole in chassis.) Install new switch and coil assembly in the hole that the switch extension shaft previously went through. After placing switch in hole, use Hex Nut supplied with the kit to hold switch in place. To ensure proper operation of switch, rotate switch to position where wiper is making with 1 pf capacitor and rotate band switch on front panel to the 10-meter position. With these two switches in the above positions, the coupling can now be replaced on the shaft of the switch. Take one of the screws previously used to hold switch bracket in place and secure new bracket to chassis at hole adjacent to base of tube socket for V101.

5. Connect the wires on the new assembly as follows:

- (a) Connect the bare lead common to C130 thru C134 to the ground terminal adjacent to base of tube socket for V101.
- (b) Connect the bare lead coming from the contact on the switch to Pin 1 of V101.
- (c) Connect C112 and R104 to the single lug on the terminal strip of the new assembly.
- (d) On the input matching switch, the 40-meter and the 20-meter positions are tied together. The bare wire from these contacts has not been connected to the proper tap on the input matching coil. There are two available taps on the coil for the connection of this lead. Neither of these taps have any other connections. To determine the proper tap, the VSWR should be checked on 40-meters. Connect the bare wire to one of these taps. Should the VSWR between the exciter and linear amplifier be high, the bare wire should be moved to the other tap. The selection of the proper tap will minimize the VSWR between the exciter and the linear.

CHANGES TO TECHNICAL DESCRIPTION AND OPERATING INSTRUCTION MANUAL

Page 7 (Input Circuit)

Change 1st paragraph to read as follows:

A broadband input circuit which includes a tapped coil L112, couples the RF drive from an exciter to the cathodes of the amplifier tubes V101 and V102. This circuit is connected through switch S103 which is mechanically coupled to the bandswitch S102. It automatically selects the proper tap on L112 to which the input is connected for best drive efficiency.

Schematic Diagram

Disregard Schematic Diagram in present manual, use new Schematic Diagram attached to these instructions.

PARTS LIST

<u>SCHEMATIC DESIGNATION</u>	<u>HAMMARLUND PART NO.</u>	<u>DESCRIPTION</u>
C129	1509-01-01018	Capacitor, Disc ceramic .1 MFD +80 -20%, 100V.
C130*	1519-01-00023	Capacitor, Dur-mica DM-15, 1 pf <u>+5</u> pf, 500V.
C131*	1519-01-00086	Capacitor, Dur-mica DM-15, 33 pf <u>+2</u> %, 500V.
C132*	1519-01-00056	Capacitor, Dur-mica DM-15, 62 pf <u>+2</u> %, 500V.
C133*	1519-01-00007	Capacitor, Dur-mica DM-15, 220 pf <u>+2</u> %, 300V.
C134*	1519-01-03002	Capacitor, Dur-mica DM-19, 510 pf <u>+5</u> %, 500V.
L110**	1806-02-00040	Choke, parasitic.
L111**	1806-02-00040	Choke, parasitic.
L112*	1804-02-00061	Coil, Input matching.
R122**	4705-01-00928	Resistor, fixed 470 ohm <u>+10</u> %, 2W.
R123**	4705-01-00928	Resistor, fixed 470 ohm <u>+10</u> %, 2W.
R124**	4705-01-00928	Resistor, fixed 470 ohm <u>+10</u> %, 2W.
R125**	4705-01-00928	Resistor, fixed 470 ohm <u>+10</u> %, 2W.
S103*	5106-02-00021	Switch, Input matching.
	3123-01-00011	Washer, shoulder
	1450-02-00183*	Bracket
	2885-01-00024*	Terminal strip.
	2806-51-06116*	Screw, Steel 6-32 x 1/2 Lg.
	2898-63-31000*	Lockwasher.
	6003-01-00005*	#18 Buss wire.
	2117-02-00002**	Clip, Tube cap.
	2888-26-13000	Terminal
	2898-63-11006	Washer, flat
	2893-51-17101	Nut, hex.

NOTE: *These parts are part of Input matching assembly, #9010-03-00017.
 **These parts are part of Parasitic RF inductor assembly,
 #9010-03-00016.

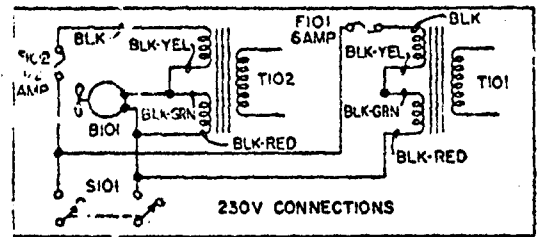
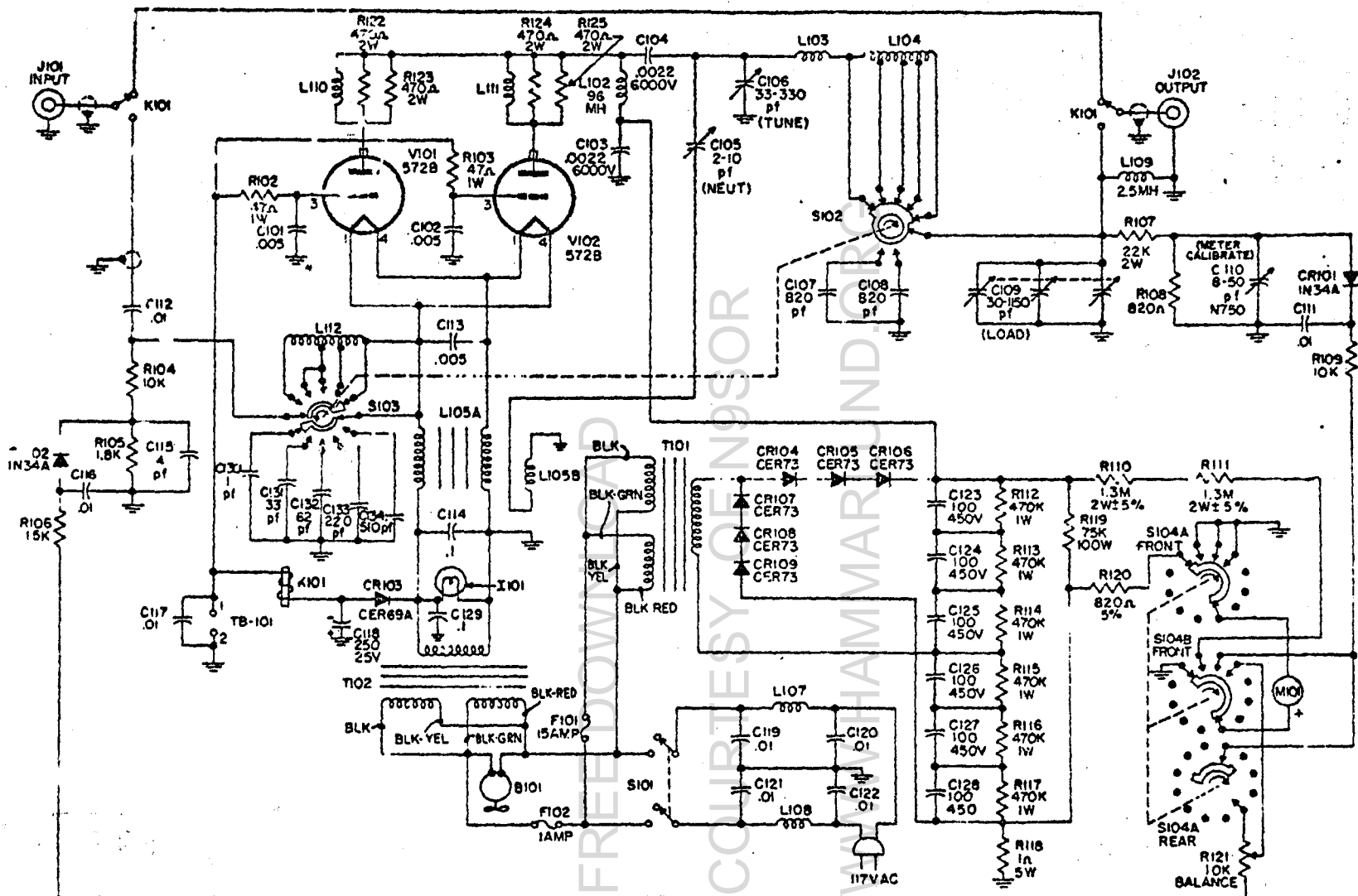

- NOTES
- 1 ALL CAPACITOR VALUES ARE IN MICROFARADS UNLESS OTHERWISE SPECIFIED
 - 2 ALL RESISTORS ARE 1/2W ±10% UNLESS OTHERWISE SPECIFIED
 - 3 S102 & S103 SHOWN IN 10M POSITION
 - 4 S104
 - 1- PL MA
 - 2- PL HV
 - 3- RF VOLTS
 - 4- LINEARITY
 5. S104 SHOWN IN PL MA POSITION
 6. WHEN 230V CONNECTION IS USED, CHASSIS SHALL BE CONNECTED TO POWER GROUND.

SCHEMATIC DIAGRAM
LINEAR AMPLIFIER (HXL-ONE)

**Installation Instructions for Code #2
Modification Kit #9010-14-00002
to HXL-1 Linear Amplifier**

Dear HXL-1 Owner:

This bulletin has been prepared in order to provide you with the necessary information to eliminate a possible self-oscillating condition in the HXL-1 linear amplifier.

It should be noted that when purchasing replacement 57B tubes for use in the HXL-1, one should visually inspect the tubes. Check the spacing between the Getter and Plate Structure. There should be at least 1/4" spacing between these elements in order to prevent arcing.

The following is a step by step procedure that should be followed. Before making the changes outlined in this bulletin, the linear amplifier must have code #1 modification (Hammarlund Part #9010-14-00001) installed in it. This can be identified by the capacitors C130 through C134 in the input circuit, as well as L110, L111 and R122, R123, R124, R125 in the plate circuit. Some early manufactured units do not incorporate the 5 capacitors in the input circuit or the 2 parasitic suppressor assemblies.

**ALL NECESSARY WIRING CHANGES ARE ON SMALL
CHASSIS HOLDING TWO TUBE SOCKETS REFER TO
FIGURES, PAGES 4 & 5 OF THIS BULLETIN.
REMOVE TUBES AND MARK FOR REPLACEMENT IN
PROPER SOCKET AFTER MODIFICATION.**

1. Unsolder and remove as a unit, L105A and L105B (Bifilar Coil Assembly).
2. Remove filament wiring (4 brown wires from TB1 to Tube Sockets) and discard.
3. Soften solder on terminal strip TB1 rivet and rotate terminal strip 45° clockwise until parallel with edge of tube tray, as per illustration.
4. Disconnect and remove C118, (250uf capacitor) turn 180° and remount; do not connect at this time.

NOTE: DO NOT SOLDER CONNECTIONS UNTIL SO NOTED

5. Disconnect white blue and white black wires from terminal strip TB2 and TB3. Pull back to relay, twist together, dress across chassis to C118 and up to tube socket area.
6. Disconnect brown wire from TB3, pull back out of cable harness through square hole to front of partition, splice on 6 inches of wire, solder wires, tape junction and route along front of partition through hole in partition with RG8U coax and lay along side of tube tray near C118.
7. Unsolder red filament transformer leads from terminal strip TB3.
8. Remove diode (CR103) and .1 ufd disc (C114) from terminal strip TB3.
9. Remove terminal strip TB3 by breaking off. Leave rivet soldered to chassis.
10. Place a lug (Part #2888-26-01000) under the 10-32 screw that holds the plate choke.
11. Connect C118 Positive Lead to lug added in step 10 and solder.
12. Drill (2) holes in tube tray per attached drawing.
13. Mount new terminal strip (Part #2885-01-00012) in the small hole using screw and Keps nut and spot solder to tube chassis. This replaces the old terminal strip TB3.
14. Remove grommet from top center hole and place in the new hole.

NOTE: DO NOT SOLDER CONNECTIONS UNTIL SO NOTED

15. Replace red filament transformer leads to the new terminal strip TB3, lugs 2 and 3. Keep the wires close together and close to the chassis.
16. Mount a new diode (Part #4804-02-00002) Type CER69A between lugs 1 and 3 of TB3. (Cathode end on lug 3, see bottom view, Page 4.)
17. Mount the new .1uf @100V disc capacitor (C114) to the new terminal strip TB3 between lugs 2 and 3.
18. Connect the C118 negative lead to the terminal strip TB3, lug 1.
19. Connect the brown lead from step #6 to the new terminal strip, lug 3.

20. Connect white/black lead to the new terminal strip, TB3, lug 1, shorten wire to fit.
21. Connect white/blue lead to the junction of R102 and R103 on TB2. Shorten wire to fit.
22. Add a .01uf (Part #1509-01-01011) C135 disc capacitor to the same point as white/blue lead on TB2 and other end to ground; solder connections.
23. Add new filament wires between the tube sockets and the terminal strip (TB1) which was rotated in step 3. Keep the wires to each tube close together and close to the chassis. Solder at tube sockets.
24. Mount bifilar coil assembly (L105A) to the terminal strips. Connections to TB1 are as before. Connections to TB3 are as follows:
 - a. 2 bare leads from L105A to lugs 2 and 3 of TB3.
 - b. Covered heavy insulated lead from L105B to lug 2 on TB3.

Figure shows bifilar coil assembly (L105A & L105B) off to side of tube tray for better clarity of wiring. Assembly is to be mounted directly over terminal strips TB1 and TB3. This is necessary to insure proper operation.

NOTE: BEFORE SOLDERING, RECHECK WIRING FOR CORRECTNESS
SOLDER ALL CONNECTIONS ON ALL TERMINAL STRIPS

25. Route the long coil wire (L105B) through the new grommet location to top of chassis and connect to the rotor of C105 and solder.
26. Squeeze parasitic chokes (L110 and L111) together until overall dimension from outside of first turn to outside of last turn is 9/16". (Located on top of plate choke going to two tubes.)

PARTS LIST

<u>Symbol</u>	<u>Hammarlund Part Number</u>	<u>Description</u>
C114	1509-01-01018	Capacitor .1Mfd
C135	1509-01-01011	Capacitor .01 Mfd
CR103	4804-02-00002	Silicon Diode CER69A
Item 1	2888-26-01000	Solder Lug
Item 2	2885-01-00012	Terminal Strip
Item 3	6006-01-00011	Lead Wire 6"
Item 4	6006-01-00411	Lead Wire 15" (FIL.)
Item 5	2806-51-06108	Screw #6-32 x 1/4 Lg.
Item 6	2894-51-06100	Keps Nut

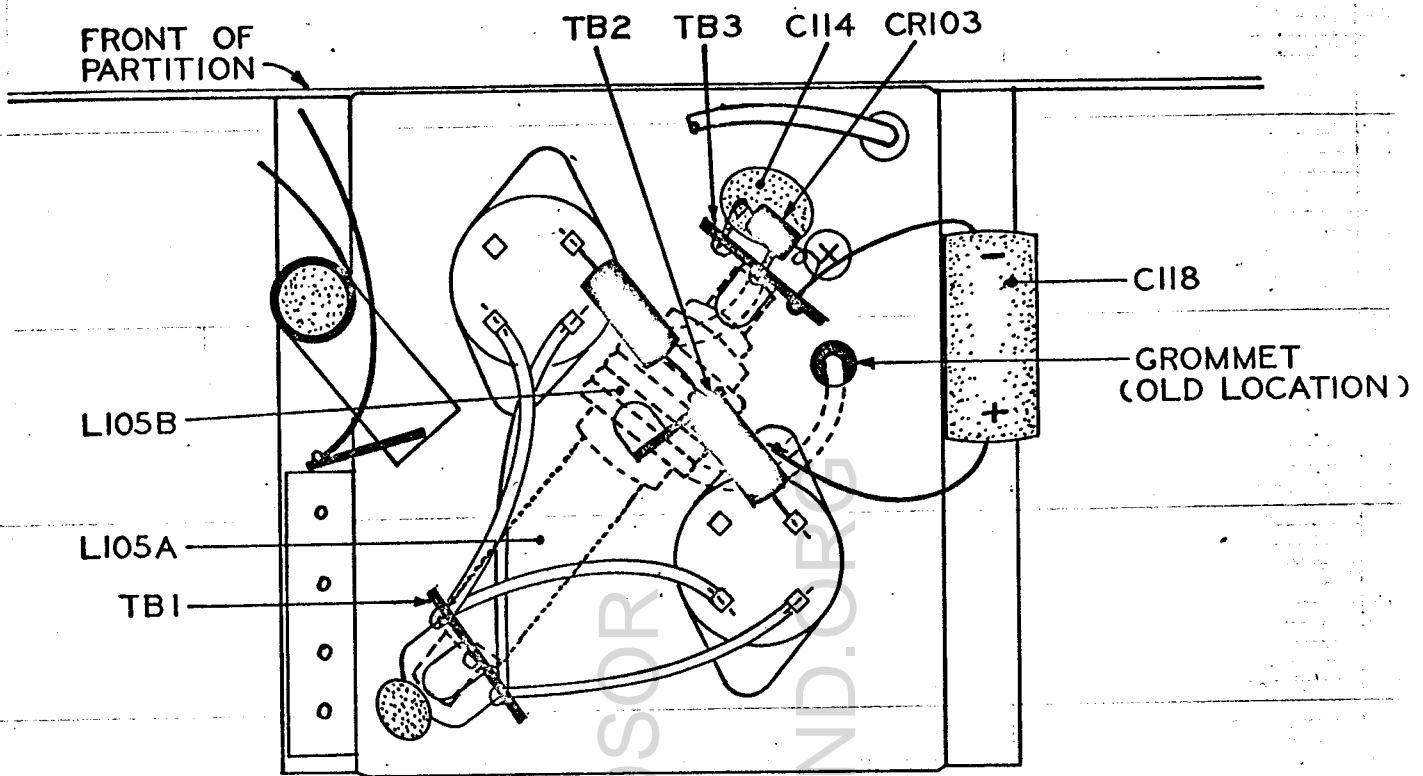

BOTTOM VIEW OF TUBE TRAY BEFORE CODE 2 MODIFICATION

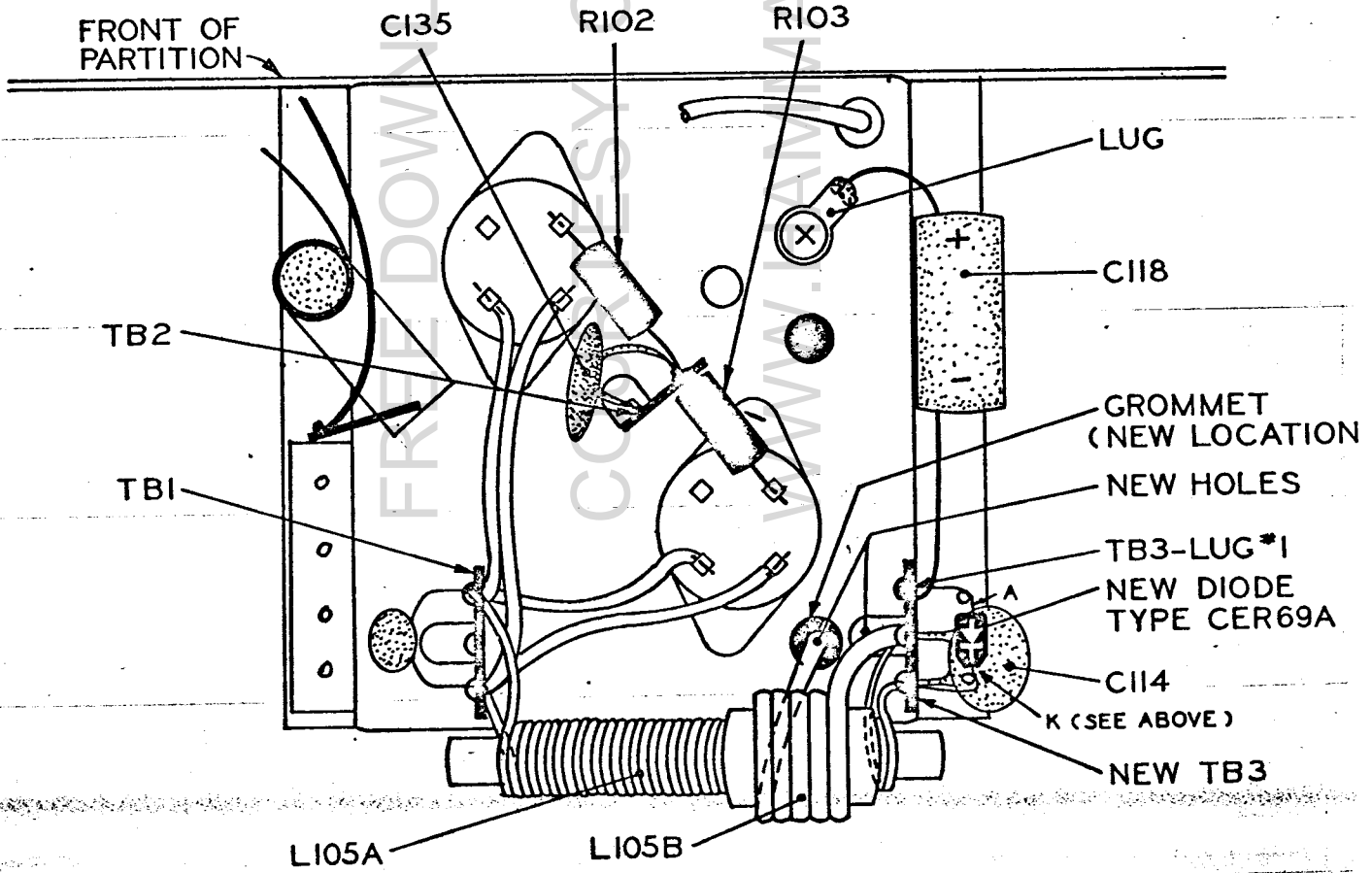
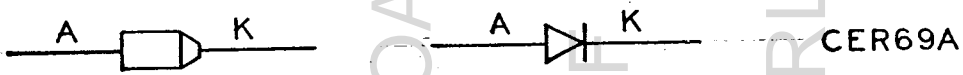

BOTTOM VIEW OF TUBE TRAY AFTER CODE 2 MODIFICATION

PARTITION

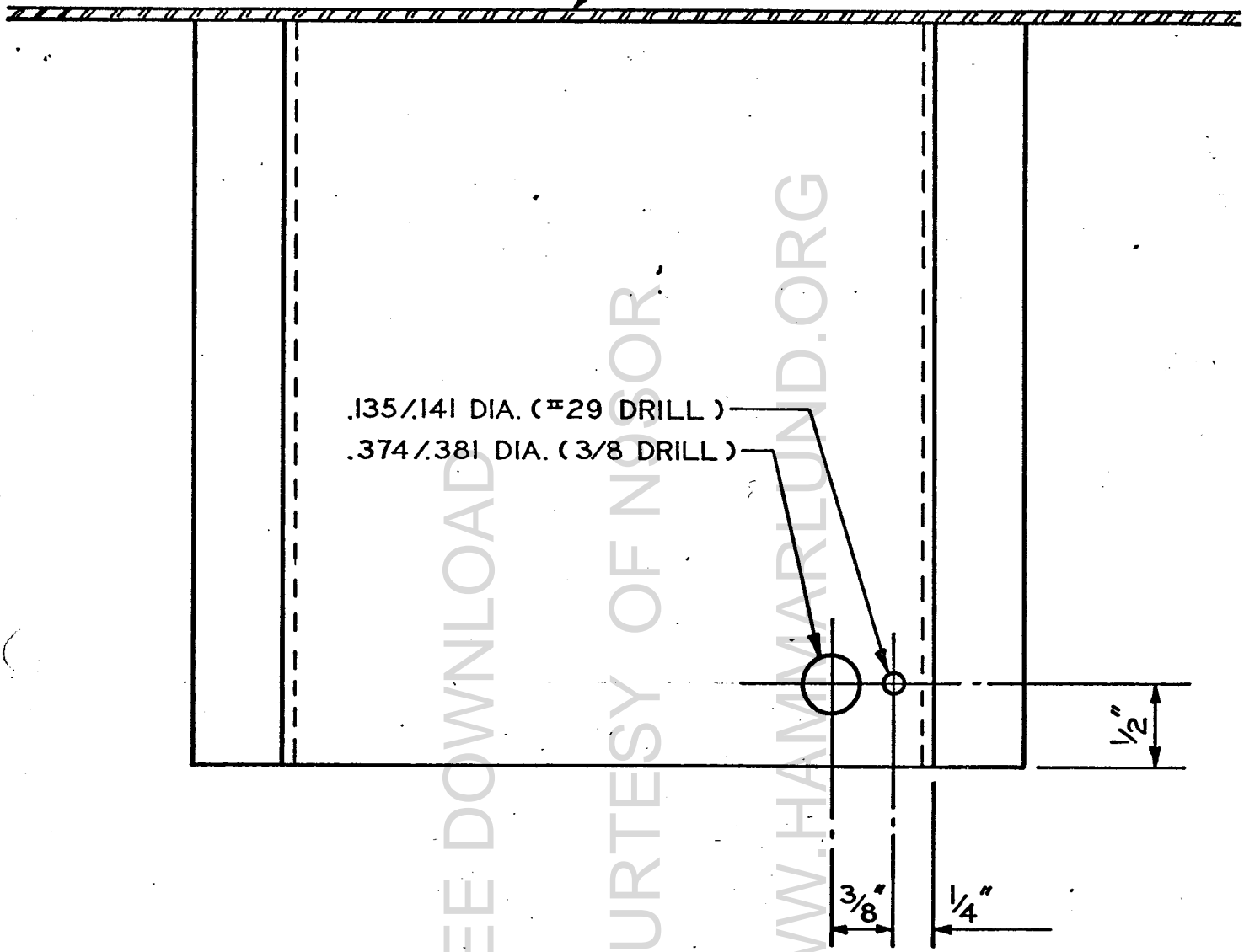

BOTTOM VIEW OF TUBE TRAY SHOWING FIELD DRILLED HOLES
CODE 2 MODIFICATION - STEP 12