

CARRIER OPERATED  
RELAY KIT

FOR INSTALLATION IN THE MR 50/60 AND FM 150/160 SERIES EQUIPMENT

HAMMARLUND PART NO. PL 53260-G1

INSTALLATION INSTRUCTIONS

FREE DOWNLOAD



COURTESY OF N9SOR

WWW.HAMMARLUND.OFG

MARKETING & DISTRIBUTION  
OUTERCOM ELECTRONICS CORP.  
502 Charlottetown Mall  
Charlotte, North Carolina

Telephone 333-8689 Area Code 704  
Cable Address "outercom"

THE USE OF THE CARRIER OPERATED RELAY IN FM 50/60 SERIES OF EQUIPMENTS IN MOBILE SERVICE IS NOT RECOMMENDED BECAUSE OF THE VOLTAGE VARIATIONS ENCOUNTERED IN MOBILE SERVICE. FOR SPECIAL APPLICATIONS COMMUNICATE WITH OUTERCOM ELECTRONICS CORP. ENGINEERING DEPT., 1023 SOUTH CALDWELL STREET, CHARLOTTE, NORTH CAROLINA.

## INSTALLATION

To install the carrier operated relay kit in the MR 50/60 and FM 150/160 series of equipments refer to the schematic diagram attached herein.

## THEORY OF OPERATION

Thermal noise in the FM receiver is amplified and rectified to produce a positive voltage that is reduced when a carrier is received. The stronger the carrier the less positive will be the rectified signal.

This variable DC is introduced to the grid of the pentode section of the 6BR8A. In the absence of a signal at the antenna terminals, the 10K variable cathode resistance is adjusted so that the current through the tube holds the voltage on its plate to a value below 100 volts. This is the avalanche voltage of the zener diode connected between the plate of the pentode and grid of the triode sections of V1.

When a signal is received the thermal noise is reduced, thereby reducing the DC level at the grid of the pentode section. This reduces the plate current on the tube and increases the plate voltage. When the plate voltage exceeds the avalanche voltage of the zener diode, the diode breaks down and a positive voltage is applied to the grid of the triode causing it to conduct heavily. The relay in its plate circuit will be pulled in. (energized)

External leads connected to the relay can be used to key a transmitter, turn on a light, ring a bell, etc.

## CARRIER OPERATED RELAY ADJUSTMENT

The C. O. R. assembly is mounted in a box attached to the rear of the front panel. There is only one adjustment.

With no signal input to the receiver, adjust the control (R4) to just energize the relay (contacts closed). Back off the adjustment until the relay is de-energized (contacts open). This is the most sensitive setting.

If it is desired to reduce sensitivity apply a strong signal (greater than 10 microvolts) to the receiver. Adjust R4 until the relay just operates (contacts closed). This will be the point of minimum sensitivity (approx. 1 uv). Sensitivity between minimum and maximum will be obtained with intermediate settings.

## AUTOMATIC HOLD - MANUAL RESET MODIFICATION

This modification permits the call lamp of MR-50X and MR-60X monitor receivers to remain lit after a signal has actuated the relay. Relay K1 and a 1.5 meg. resistor are so wired that the grid of the relay tube remains positive after the actuating signal has disappeared. (with S102 in its center position). Movement of S102 (on front panel of receiver) to its "RESET" position grounds the grid of the relay tube, thereby de-energizing the relay causing call lamp I-102 to extinguish. Returning switch S102 to its center position (stand-by) makes the hold-in circuitry ready to accept another carrier indication.

### PARTS LIST

<u>SCHEMATIC DESIGNATION</u>	<u>DESCRIPTION</u>	<u>HAMMARLUND PART NO.</u>
C1	Capacitor, disc ceramic .1mfd +80-20%, 100v	M23034-29
C2	Capacitor, disc ceramic .01mfd ±20%, 500v	M23034-28
CR1	Diode, zener 1w	K41214-2
K1	Relay (1 form c)	K40408- <del>2</del> 3
R1, R5	Resistor, fixed comp. 100k ±10%, 1/2w	K19309-97
R2	Resistor, fixed comp. 56k ±10%, 1w	K19310-91
R3	Resistor, fixed comp. 470k ±10%, 1/2w	K19309-113
R4	Resistor, variable 10k ±20%, 1w	K15381-3
R6	Resistor, fixed comp. 2.2 meg. ±10%, 1/2w	K19309-129
V1	Tube electron (6BR8A)	K40907-1

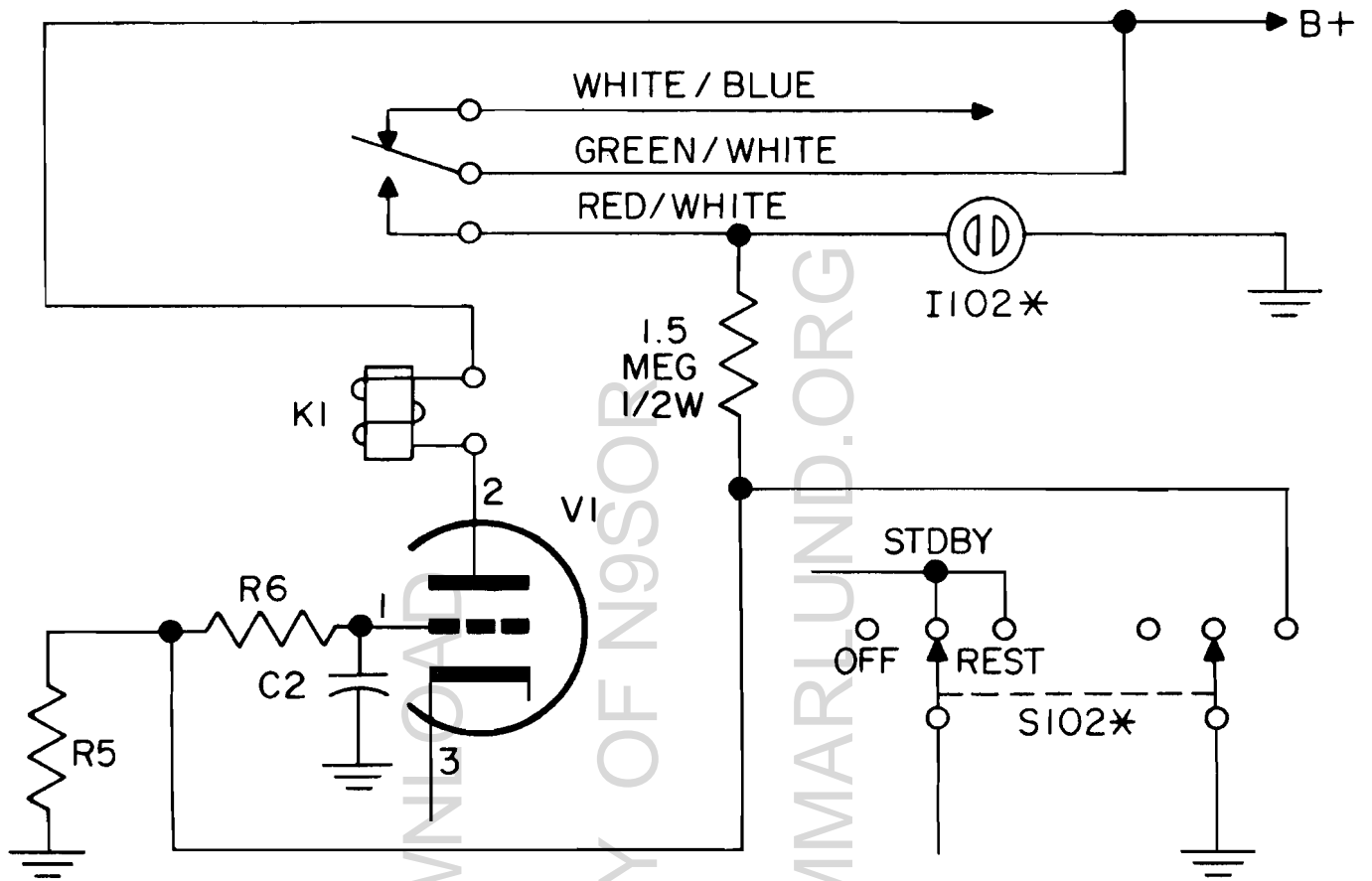

\* DENOTES COMPONENTS IN MR50X OR MR60X

MONITOR REC. CARRIER OPER. RELAY  
 AUTO. HOLD- MANUAL RESET MOD

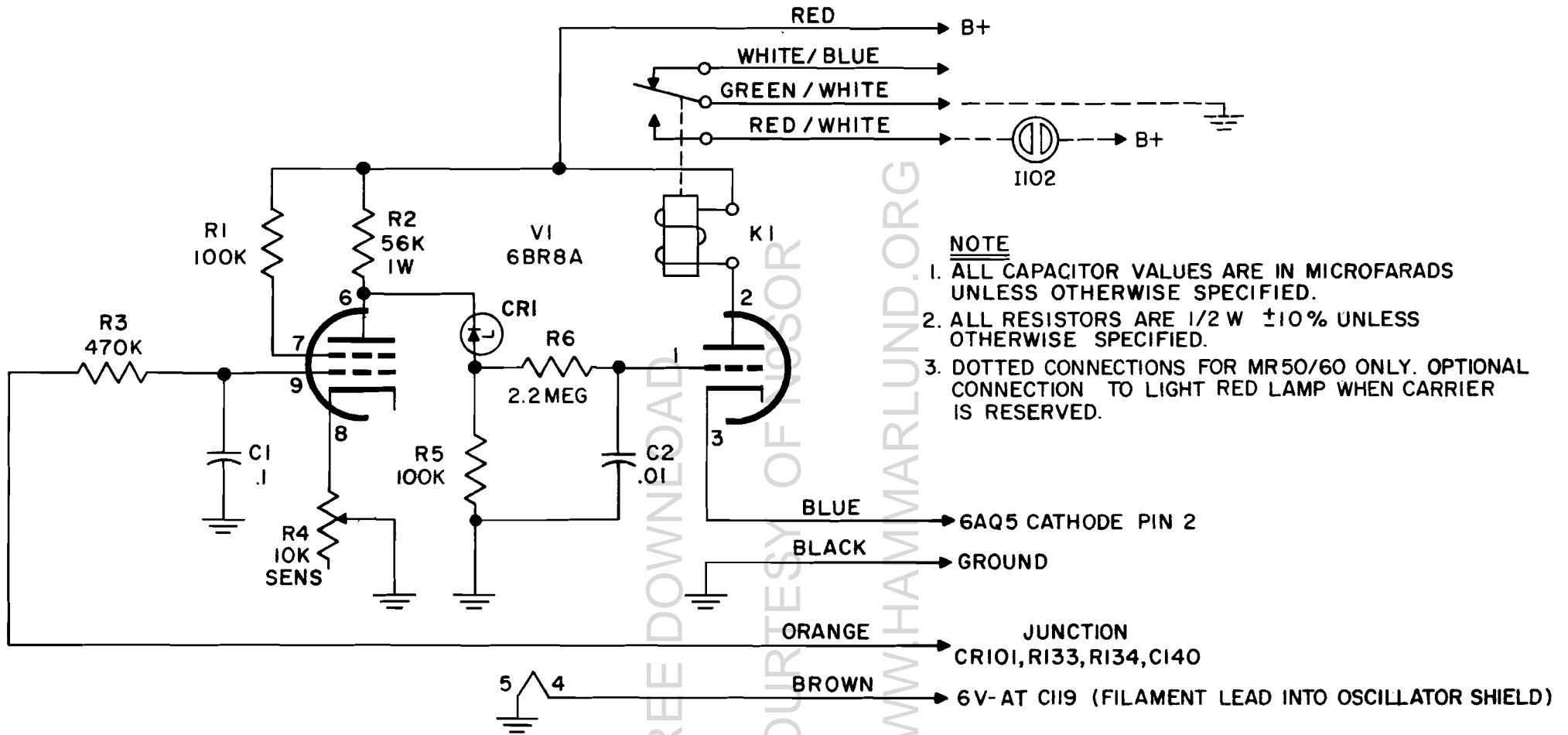

SCHEMATIC DIAGRAM  
CARRIER OPERATED RELAY

No. 53251

|| M

PRIMARY POWER WIRING-STANDARD TRUNK-MOUNT INSTALLATION  
12 VOLT INSTALLATIONS ONLY

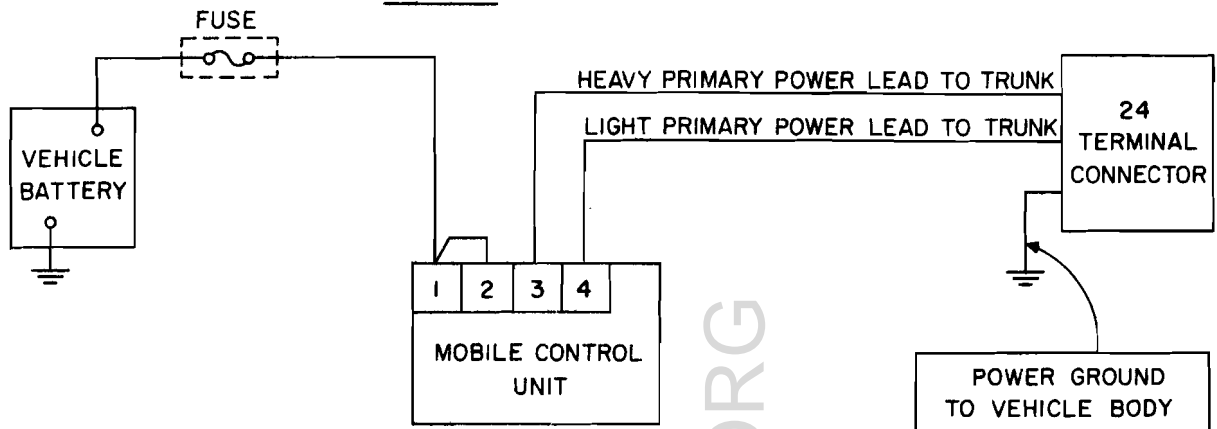

PRIMARY POWER WIRING-PRIMARY POWER RELAY INSTALLATIONS

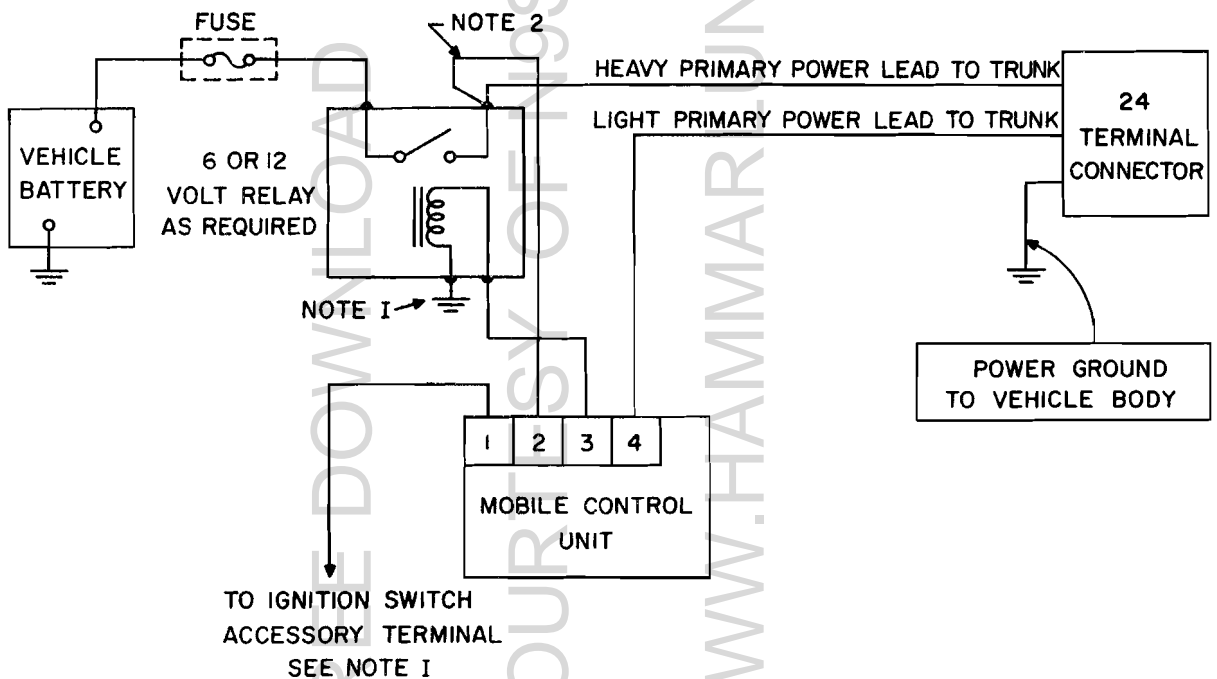

NOTE I: IN VEHICLES NOT EQUIPPED WITH AN ACCESSORY CIRCUIT ON THE IGNITION SWITCH AUTOMATIC DISCONNECT OF THE RECEIVER-TRANSMITTER UNIT DURING STARTING OF THE ENGINE MAY BE ACHIEVED BY RETURNING THIS LEAD TO STARTER "HOT" TERMINAL INSTEAD OF GROUND (MAKE CERTAIN THAT THE HOT TERMINAL OF THE STARTER AND NOT THE STARTER SOLENOID IS USED).

NOTE 2: ON 12 VOLT SYSTEMS IT IS PERMISSIBLE TO DELETE THIS LEAD AND ADD A JUMPER BETWEEN TERMINALS 1 & 2 OF MOBILE CONTROL UNIT.