



Installation and Operating Instructions for the Hammarlund I.F. Noise Silencer Accessory

INTRODUCTION

The Hammarlund I.F. Noise Silencer Accessory has been designed to be easily installed in the Hammarlund Models HQ-170 and HQ-180 Communication Receivers. The Noise Silencer Assembly contains three vacuum tubes (types 6BE6, 6BH6 and 6AL5), I.F. Adaptor Socket Assembly and associated components.

The Noise Silencer circuitry is introduced into either Communication Receiver in the identical manner electrically (between V4 and T4 in either receiver via the Adaptor Socket); however the physical location of the Silencer unit in each equipment is somewhat different due to the receiver design differences. See photographs for the location of the Noise Silencer in each receiver.

INSTALLATION

(a) Tools Required

1. Hollow Shaft Hex Nut Drivers for 1/4, 5/16 and 1/2" Nut Sizes.
2. Small set-screw type of a screwdriver.
3. Small soldering iron.
4. Phillips Head Screwdriver - #4 size.

(b) Items Supplied in the Noise Silencer Kit

- | 1. Qty. | Item Description | Hammarlund Pt. No. |
|---------|---|--------------------|
| 1 | Concentric Shaft Variable Resistor | |
| 2 | Section with SPDT Switch | K38976-2 |
| 1 | Knob with set screw | K26241-1 |
| 1 | Knob with set screw | K26242-1 |
| 1 | Bracket (required for HQ-180 only) | K26512-1 |
| 2 | Screw, Thread Cutting 4/40 x 1/4 lg. (required for HQ-180 only) | M11842-40 |
| 1 | Hex Nut 3/8-32 | K10012-29 |
| 1 | Lockwasher 3/8, Internal Tooth | K10053-14 |
| 1 | Tube Shield for Adaptor Socket | K16615-8 |
| 1 | Instruction Sheet | K26504-1 |

INSTALLATION PROCEDURE FOR THE HQ-170 ONLY

Remove three rear cabinet screws with 5/16" Hex Nut Driver. Loosen set screw on clock shaft knob and remove knob. Loosen top cabinet screw by 3 to 4 turns and remove chassis from cabinet. Turn chassis so that left side rests on the table.

In the Model HQ-170 Receiver, the Noise Silencer sub-chassis is fastened to the Receiver chassis by means of the same self tapping Hex Head screws which are used to fasten the Selectivity-Sideband Switch bracket to the chassis. Loosen the Hex Head self threading screws sufficiently so that when the silencer chassis is placed in its correct position as shown in photograph Fig. 1 it will be flush up against the receiver chassis. Then tighten both screws while firmly pressing the sub-chassis up against receiver chassis.

Loosen set screw on Noise Limiter knob, remove knob. Remove 3/8 Hex Nut on Noise Limiter control and push shaft through hole. Place 3/8 Lockwasher on new concentric control shaft and insert into panel. Fasten control to front panel with 3/8 Hex Nut. Unsolder wires individually from old control and re-solder to the new control (rear section with switch) in exactly the same position as on the old control, as in Fig. 5.

Insert inner and outer shaft knobs onto Noise Silencer Control Shafts. Adjust each knob properly and tighten set screw on each knob.

Insert Red wire (B+) and Black wire (FIL) through large hole directly below the AM-SSB switch, and connect to the proper lug on strip and tube socket as shown in Figure 3. Remove V4-6BA6, 455 KCS I.F. Amplifier tube from its socket. Insert the Silencer Tube Socket Adaptor in this socket. Insert the 6BA6 tube in the Tube Socket Adaptor and cover the tube with the New Tube Shield (Twist-lock type).

INSTALLATION PROCEDURE FOR MODEL HQ-180 ONLY

In the Model HQ-180 Receiver, the Noise Silencer Sub-Chassis is fastened to the spade inverted lug which is located on the top-rear end plate of Bandsread tuning gang (right gang). See Fig. 2. First, fasten the adaptor bracket to the Noise Silencer Sub-Chassis with the two 4/40 x 1/4 lg. thread cutting screws. Then, remove the Pal-Nut located on the Bandsread Tuning gang rear end plate. Place the Silencer Sub-Chassis on top of the capacitor dust cover with the spade lug protruding through Adaptor Bracket. Fasten the Sub-Chassis to the Bandsread Tuning Gang with the Pal-Nut.



Figure 1 – Location of I.F. Noise Silencer in Model HQ-170 Receiver

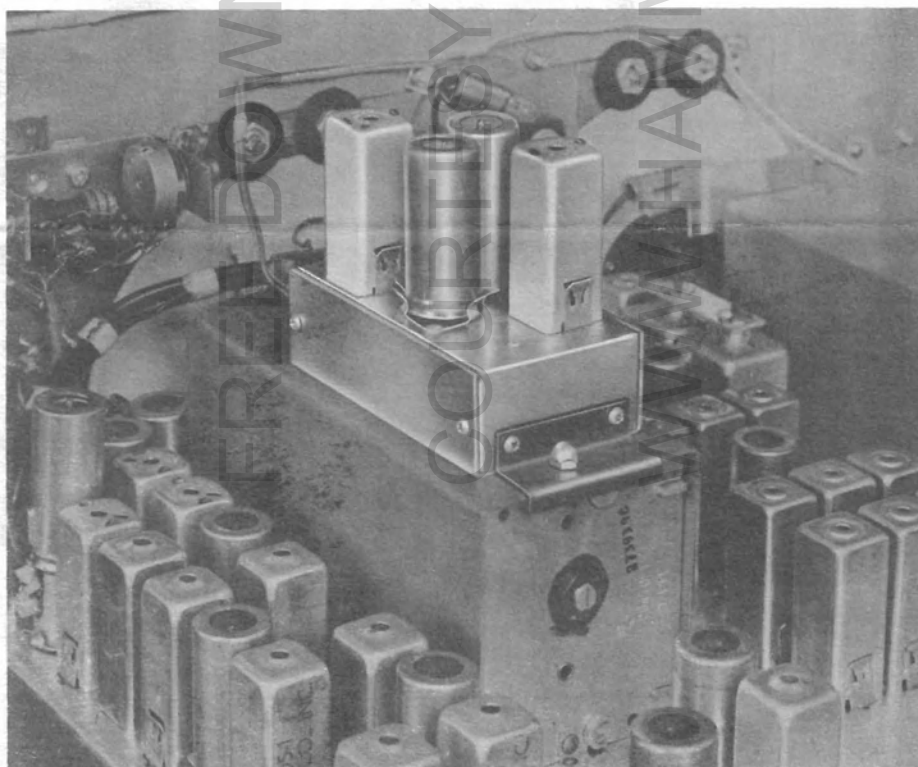

Figure 2 – Location of I.F. Noise Silencer in Model HQ-180 Receiver



Loosen set screw on Noise Limiter knob, remove knob. Remove 3/8 Hex Nut on Noise Limiter control and push shaft through hole.

Place 3/8 Lockwasher on new concentric control shaft and insert into panel. Fasten control to front panel with 3/8 Hex Nut.

Unsolder wires individually from old control and re-solder to the new control (rear section with switch) in exactly the same position as on the old control, as shown in Fig. 5.

Insert inner and outer shaft knobs onto Noise Silencer Control Shaft. Adjust each knob properly to match Panel Markings and tighten set screw on each knob.

Insert Red wire (B+) and Black wire (FIL) through large hole directly below the AM-SSB switch, and connect to the proper lug on strip and tube socket as shown in Figure 4. Remove V4-6BA6, 455 KCS I.F. Amplifier tube from its socket. Insert the Silencer Tube Socket Adaptor in this socket. Insert this tube in the Tube Socket ADAPTOR and cover the tube with the New Tube Shield (Twist-Lock type).

Note: After installation, in either the HQ-170 or HQ-180, locate lead wires connecting the Noise Silencer sub-chassis to the new dual control, along the front panel above the dial scales, in the space between the front panel and the fiber washers.

OPERATION

After the I.F. Noise Silencer has been installed in either the HQ-170 or HQ-180 Receiver, both the existing Noise Limiter and the new I.F. Noise Silencer can be used independently or together. The existing noise limiter is an audio amplitude limiting device. The circuitry and operation of this limiter remains unchanged, and is controlled by the smaller knob which also operates the switch. This knob is normally adjusted to the extreme counterclockwise position (Limiter-OFF) and is turned clockwise to increase the degree of audio limiting in the presence of undesired noise.

A considerable degree of noise reduction is accomplished with this type of noise limiter. The Noise Limiter however cannot prevent noise peaks from overloading the previous stages.

The I.F. Noise Silencer is introduced into the approximate middle of the communications receiver circuitry to "silence" (render inoperative) the receiver during the short duration of time of any individual noise pulse. The listener will not hear the "hole" because of its short duration and very effective noise reduction is obtained. The larger of the concentric knobs controls the degree of I.F. Noise silencing or threshold. This knob is normally adjusted to its extreme counter-clockwise position (Silencer-OFF) and is turned clockwise for increasing effectiveness.

When noisy reception exists the Silencer knob is turned clockwise up to the position where distortion in the audio modulation becomes noticeable. It is desirable to use the least amount of silencing to effectively suppress the undesired noise. The knob should be adjusted to suit listening conditions. The exact knob position is not critical and depends upon the relative signal strength of the signal, noise and also the type of noise (waveform).

This type of noise silencing will usually be found more effective on CW and SSB making possible the reception of signals that could not be heard without the silencer due to heavy ignition or other pulse type noise.

THEORY

The I.F. Noise Silencer chassis contains two I.F. Amplifier circuits. One circuit consisting of V201 (6BE6) is a relatively low gain "noise controlled" I.F. Amplifier. It is inserted in the communications receiver between V4 (6BA6) plate and the I.F. Transformer T4 by means of the Adaptor Socket. In the presence of noise a negative rectified noise voltage is impressed upon the outer grid (pin 7) of the 6BE6 which results in a large decrease in amplification of this stage.

The grid (pin 1) of V202 (6BH6) is connected to the same I.F. input as the 6BE6, however, the output of this high gain I.F. Noise Amplifier stage feeds into a diode detector circuit (V203B) which demodulates the I.F. signal. The detected output is connected to the "Noise controlled" amplifier (V201) by means of the coupling capacitor C206 and R.F. Choke L200. The R.F. Choke presents a very high impedance to the I.F. signals but allows the detected noise pulses to pass through to the outer grid pin 7 (V201). Diode V203A which is connected from pin 7 (V201) to ground short circuits the positive excursion of the noise pulses. Only negative noise pulses can actuate the 6BE6 tube.

The Level Adjust Control R207A located on the front panel adjusts the amount of I.F. gain of the Noise Amplifier tube (V202-6BH6). Since the Noise Amplifier circuits can amplify the modulated signal as well as the undesired noise too much gain must be avoided. Excessive noise amplifier gain will cause the overall amplification to be varied by the distorted waveform that is present on pin 7 of the 6BE6 resulting in a noticeable degradation of speech in the loudspeaker. This control must be adjusted to suit existing signal and noise conditions.

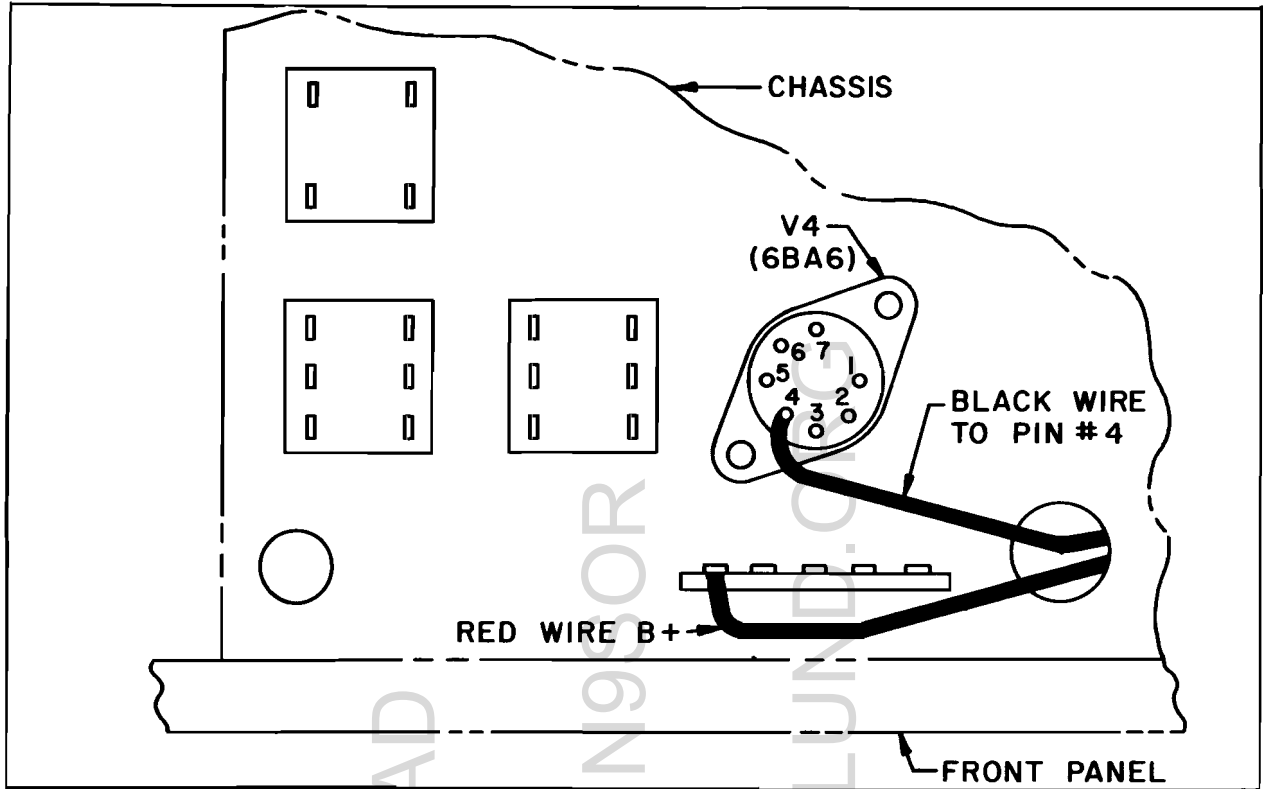

Figure 3 - HQ170 Bottom View of Chassis Showing New Connections from I.F. Noise Silencer.

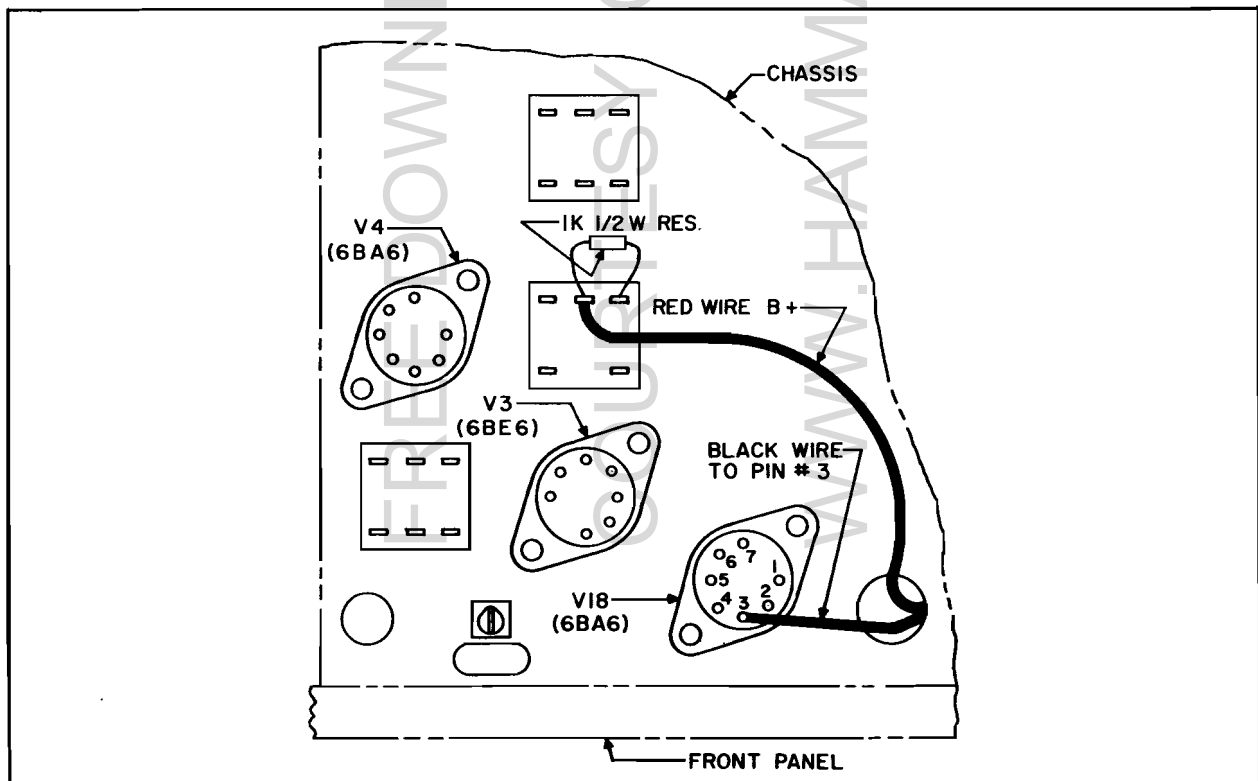

Figure 4 - HQ-180 Bottom View of Chassis Showing New Connections from I.F. Noise Silencer.



ALIGNMENT OF THE I.F. NOISE SILENCER

The I.F. Noise Silencer has been factory aligned and tested at 455 Kcs in an actual Hammarlund Communications receiver. Introduction of the Silencer into either receiver normally does not require a touch up alignment of the Receiver or Silencer.

If it becomes necessary to re-align the HQ-170 or HQ-180 receiver after the silencer is installed, it is suggested that the receiver be re-aligned with the Silencer removed electrically from the chassis. This is accomplished by unplugging the adaptor socket from chassis socket and insert the 6BA6 (V4) I.F. tube into the chassis socket.

After the receiver has been aligned as outlined in its Instruction Book, re-insert the Adaptor Socket and align T201 (top and bottom coils) in the same test equipment set-up. When aligning T201 the I.F. Noise Silencer knob must be in the Off position (Maximum counter-clockwise).

To align T202 (the Noise Amplifier I.F. transformer) the bottom cover of the Silencer Unit must be removed. Connect a VTVM (on negative D.C. volts) across R211. Turn I.F. Noise Silencer knob maximum clockwise, adjust 455 Kcs Signal Generator input to Receiver to read approximately -5 volts d.c. and peak top and bottom slugs.

VOLTAGE CHART

TUBE TYPE	PIN NOS.						
	1	2	3	4	5	6	7
V201, 6BE6	0	.8	0	6.3 AC	250	32	-.3 to -.6*
V202, 6BH6	0	3.6 to 22.5*	0	6.3 AC	225-250*	180-250*	0
V203, 6AL5	0	-.2 to -1.0*	0	6.3 AC	0	0	-.3 to -.6*

*Varies within these limits with adjustment of Noise Silencer Control R207A.



PARTS LIST I.F. NOISE SILENCER

SCHEMATIC DESIGNATION	DESCRIPTION	HAMMARLUND PART NO.
Capacitors		
C201	Fixed, Silver Mica, 10 mmf, 500 W.V.D.C.	K23006-8
C202, C203, C204, C206, C207, C208, C209	Fixed, Ceramic Disc, .01 mfd, 600 W.V.D.C.	K23034-19
C205, C210	Fixed, Silver Mica, 150 mmf, 300 W.V.D.C.	K23006-53
C211	Fixed, Silver Mica, 5 mmf, 500 W.V.D.C.	K23006-78
Coils		
L200	Fixed, Inductor, 10 Millihenries	K42336-1
Resistors		
R200, R208	100K ohms, 1 w., 10%	K19310-97
R201	4.7K ohms, 1/2 w., 10%	K19309-65
R202	1K ohms, 1/2 w., 10%	K19309-49
R203	220K ohms, 1/2 w., 10%	K19309-105
R204	270 ohms, 1/2 w., 10%	K19309-35
R205	470K ohms, 1/2 w., 10%	K19309-113
R206	180 ohms, 1/2 w., 5%	K19309-260
R207A	Variable, 10K (Dual Concentric)	K38976-2
R207B	Variable, 500K (Part of R207A)	
R209	27K ohms, 1/2 w., 10%	K19309-83
R210	2.2K ohms, 1/2 w., 10%	K19309-57
R211	47K ohms, 1/2 w., 10%	K19309-89
Switches		
S201	Switch SPDT (Part of R207A)	
Transformers		
T201	Transformer, 455 Kcs	K38992-1
T202	Transformer, 455 Kcs	K38829-1
Vacuum Tubes		
V201	Electron, 6BE6	K16284-1
V202	Electron, 6BH6	K16299-1
V203	Electron, 6AL5	K16294-1
Mechanical Parts		
	Knob	K26241-1
	Knob	K26242-1
	Bracket (HQ-180 only)	K26512-1
	Screw Thread Cutting #4/40 x 1/4 lg.	M11842-40
	Tube, Shield	K16615-8
	7 Pin Adaptor Assembly	M26507-G1

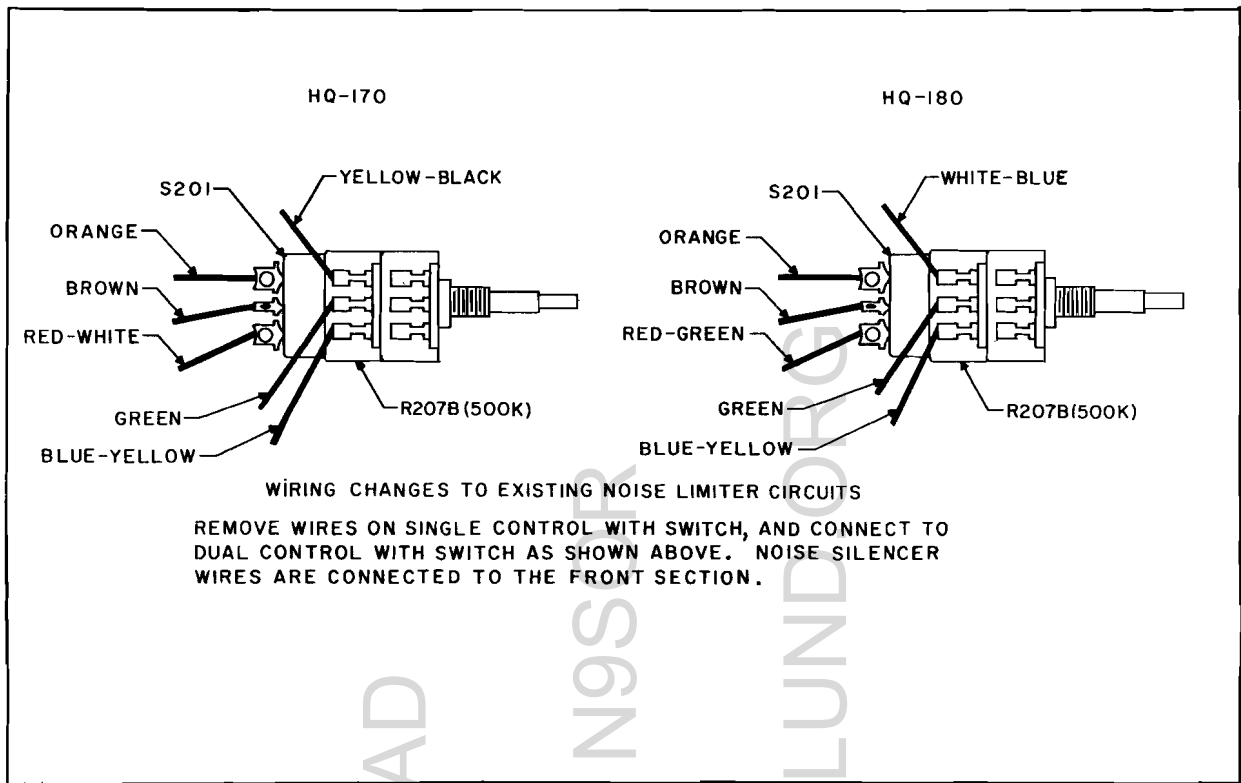

Figure 5 - Wiring of New Dual Noise Silencer Control.

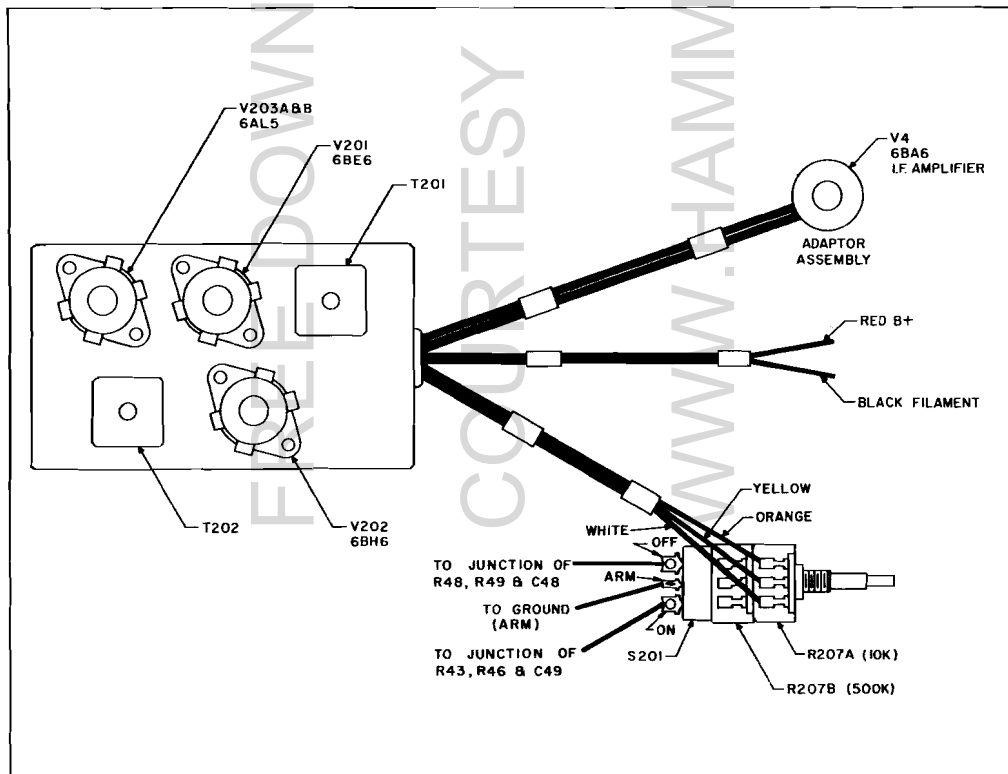

Figure 6 - I.F. Noise Silencer Accessory as supplied.

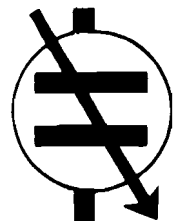
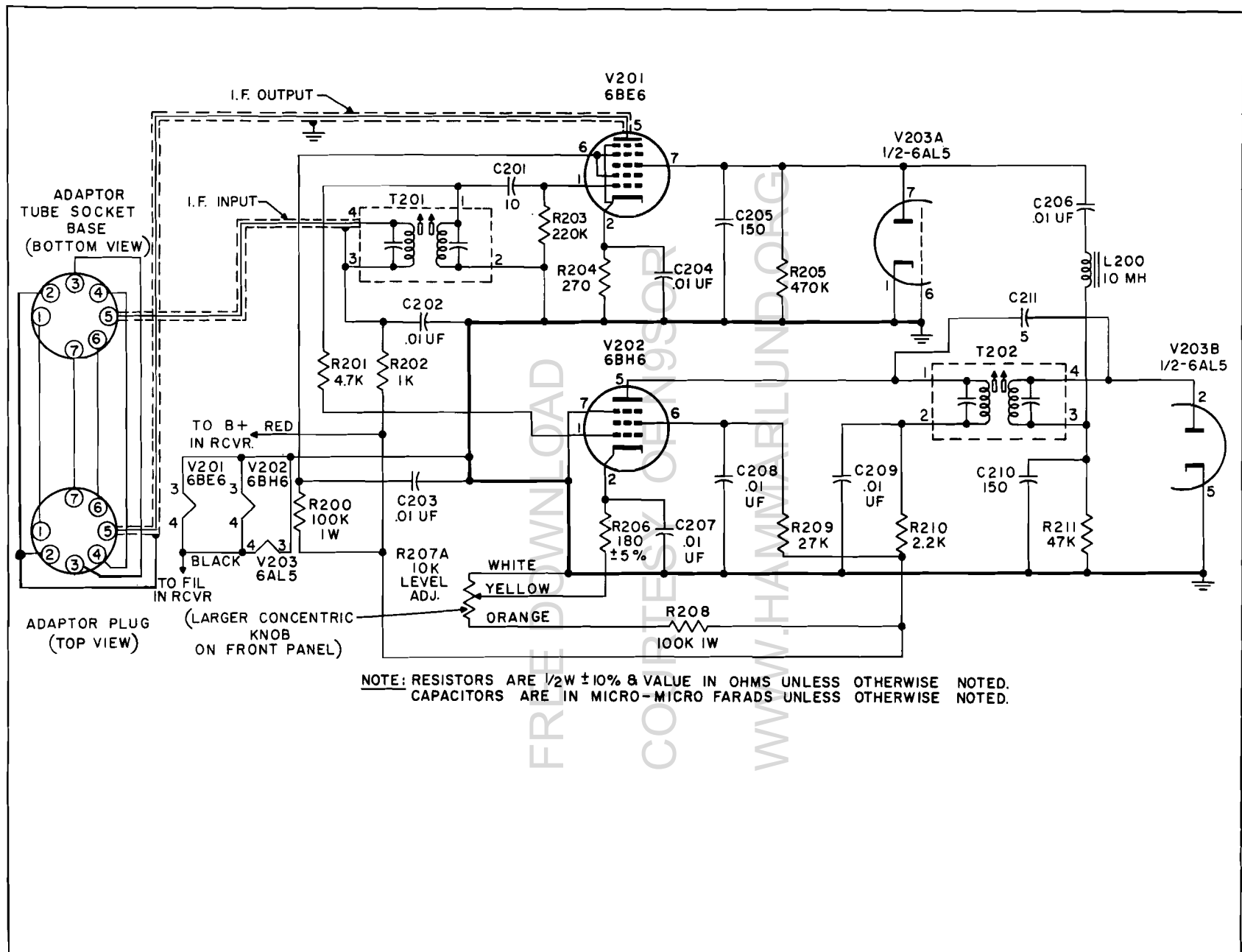

Figure 7 - Schematic I.F. Noise Silencer



Installation and Operating Instructions
for the Hammarlund I. F. Noise Immunizer

INTRODUCTION

The Hammarlund I. F. Noise Immunizer has been designed to be installed in Hammarlund (HQ-170 Series and HQ-180 Series) Communication Receivers. The Noise Immunizer contains three tubes (Types 6BE6, 6BH6 and 6AL5), and associated components.

The Noise Immunizer Circuitry is introduced into either series Communications Receiver in the identical manner electrically, (between V4 and T4). The physical location of the Immunizer in each equipment is somewhat different due to receiver design differences. (See photographs for the location of the Noise Immunizer in each series receiver.)

INSTALLATION

(a) Tools Required:

1. Hollow Shaft Hex Nut Drivers for 1/4, 5/16 and 1/2 Nut Sizes.
2. Small Set-Screw Type of Screwdriver.
3. Small soldering Iron.
4. Phillips Head Screwdriver - #4 Size.

(b) Items Supplied in the Noise Immunizer:

1. Noise Immunizer Sub-Chassis.

2. <u>Quantity</u>	<u>Item Description</u>	<u>Hammarlund Pt. No.</u>
1	Concentric Shaft Potentiometer 2 Section with SPDT Switch	K38976-2
1	Knob with Set Screw	K26241-1
1	Knob with Set Screw	K26242-1
1	Bracket(required for HQ-180 only)	K26512-1
2	Screw, Thread Cutting 4/40 x 1/4" lg. (required for HQ-180 only)	M11842-40
1	Hex Nut 3/8"-32	K10012-29
1	Lockwasher 3/8", Internal Tooth	K10053-14
1	Instruction Sheet	K26504-1

INSTALLATION PROCEDURE FOR THE HQ-170 SERIES

Remove three rear cabinet screws with 5/16" Hex Nut Driver. Loosen set screw on clock shaft knob and remove knob. Loosen top cabinet screw by 3 to 4 turns and remove chassis from cabinet. Turn chassis so that left side rests on the table.

NOTE: Insert inner and outer shaft knobs onto Noise Immunizer Control Shaft. Adjust each knob properly to match Panel Markings and tighten set screw on each knob.

After installation, locate lead wires connecting the Noise Immunizer sub-chassis to the new dual control along the front panel above the dial scales in the space between the front panel and the fiber washers.

OPERATION

After the I. F. Noise Immunizer has been installed in the Receiver, both the existing Noise Limiter and the new I. F. Noise Immunizer can be used independently or together. The existing noise limiter is an audio amplitude limiting device. The circuitry and operation of this limiter remains unchanged, and is controlled by the smaller knob which also operates the switch. This knob is normally adjusted to the extreme counterclockwise position (Limiter OFF) and is turned clockwise to increase the degree of audio limiting in the presence of undesired noise.

A considerable degree of noise reduction is accomplished with this type of noise limiter. The Noise Limiter, however, cannot prevent noise peaks from overloading the previous stages.

The I. F. Noise Immunizer is introduced into the approximate middle of the communications receiver circuitry to "Immunize" (render inoperative) the receiver during the short duration of time of any individual noise pulse. The listener will not hear the "hole" because of its short duration and very effective noise reduction is obtained. The larger of the concentric knobs controls the degree of I. F. Noise silencing of threshold. This knob is normally adjusted to its extreme counterclockwise position (Immunizer OFF) and is turned clockwise for increasing effectiveness.

When noisy reception exists, the Immunizer knob is turned clockwise up to the position where noise is suppressed. It is desirable to use the least amount of silencing to effectively suppress the undesired noise. The knob should be adjusted to suit listening conditions. The exact knob position is not critical and depends upon the relative signal strength of the signal, noise, and also the type of noise (waveform).

This type of noise immunizing will usually be found more effective on CW and SSB, making possible the reception of signals that could not be heard without the Immunizer due to heavy ignition or other pulse type noise.

THEORY

The I. F. Noise Immunizer chassis contains two I. F. Amplifier circuits. One circuit consisting of V201 (6BE6) is a relatively low gain "noise controlled" I. F. Amplifier. It is inserted in the communications receiver between V4 (6BA6) plate and the I. F. Transformer T4. In the presence of noise, a negative rectified noise voltage is impressed upon the outer grid (pin 7) of the 6BE6 which results in a large decrease in amplification of this stage.

The grid (pin 1) of V202 (6BH6) is connected to the same I. F. input as the 6BE6, however, the output of this high gain I. F. Noise Amplifier stage feeds into a diode detector circuit (V203B) which demodulates the I. F. signal. The detected output is connected to the "Noise controlled" amplifier (V201) by means of the coupling capacitor C206 and RF Choke L 200. The RF Choke presents a very high impedance to the I. F. signals but allows the detected noise pulses to pass through to the outer grid pin 7 (V201). Diode V203A which is connected from pin 7 (V201) to ground, short circuits the positive excursion of the noise pulses. Only negative noise pulses can actuate the 6BE6 tube.

The Level Adjust Control R707A located on the front panel, adjusts the amount of I. F. gain of the Noise Amplifier tube (V202-6BH6). Since the Noise Amplifier circuits can amplify the modulated signal, as well as the undesired noise, too much gain must be avoided. This control must be adjusted to suit existing signal and noise conditions.

ALIGNMENT OF THE I. F. NOISE IMMUNIZER

The I. F. Noise Immunizer has been factory aligned and tested at 455 kcs. in an actual Hammarlund Communications Receiver. Introduction of the Immunizer into either receiver normally requires a slight touchup of Transformer T4.

If it becomes necessary to realign the receiver at any time, the procedure as outlined in its instruction manual should be followed. When aligning the 455 kcs. stages, the I. F. Noise Immunizer knob must be in the OFF position (maximum counterclockwise).

To align T202 (the Noise Amplifier I. F. transformer) the bottom cover of the Immunizer Unit must be removed. Connect a VTVM (on the negative DC Volts) across R211. Turn I. F. Noise Immunizer knob maximum clockwise. Adjust 455 kcs. Signal Generator input to Receiver to read approx. -5 v. DC, and peak top and bottom slugs.

VOLTAGE CHART

TUBE TYPE	PIN NOS.						
	1	2	3	4	5	6	7
V201, 6BE6	0	.8	0	6.3 AC	250	100	-.3 to -.6*
V202, 6BH6	0	3.6 to 22.5*	0	6.3 AC	225-250*	180-250*	0
V203, 6AL5	0	-.2 to -1.0*	0	6.3 AC	0	0	-.3 to -.6*

*Varies within these limits with adjustments of Noise Immunizer Control R207A.

Vacuum Tubes

V201	Electron, 6BE6	K16284-1
V202	Electron, 6BH6	K16299-1
V203	Electron, 6AL5	K16294-1

Mechanical Parts

Knob	K26241-1
Knob	K26242-1
Bracket (HQ-180only)	K26512-1
Screw Thread Cutting #4/40 x 14" lg.	M11842-40

FREE DOWNLOAD

COURTESY OF N9SQR

WWW.HAMMARLUND.ORG

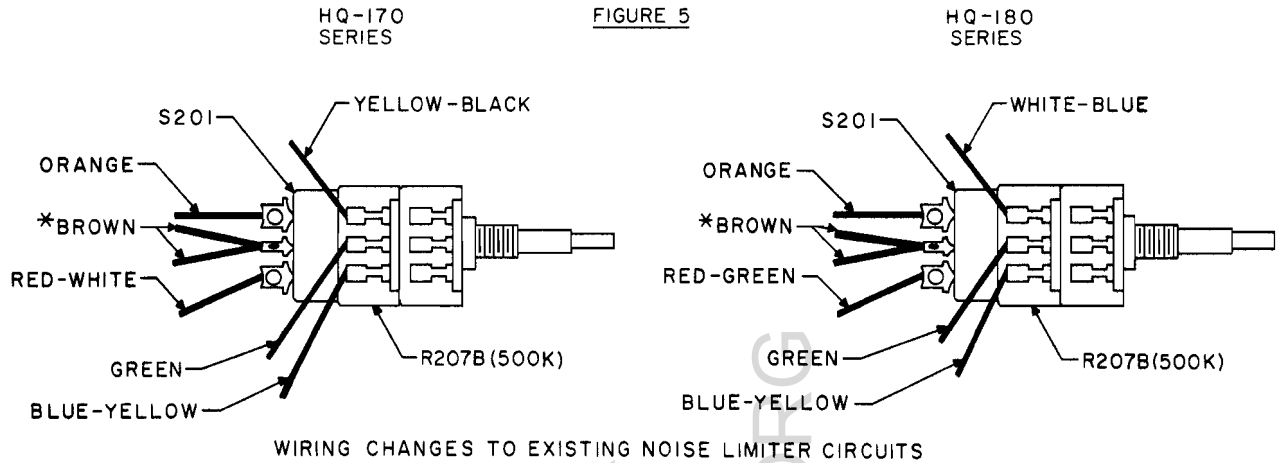

REMOVE WIRES ON SINGLE CONTROL WITH SWITCH, AND CONNECT TO DUAL CONTROL WITH SWITCH AS SHOWN ABOVE. NOISE IMMUNIZER WIRES ARE CONNECTED TO THE FRONT SECTION. * IN EARLIER HQ-170 & HQ-180 SERIES RECEIVERS, NOTE THAT THERE WERE 4 CONTACTS ON THE REAR DECK OF THE NOISE LIMITER SWITCH. THE NEW SWITCH SUPPLIED WITH THE IMMUNIZER ONLY 3 CONTACTS ARE AVAILABLE. THEREFORE 2 BROWN WIRES CONNECT TO ONE TERMINAL.

Fig. 5 - Wiring of New Dual Noise Immunizer Control.

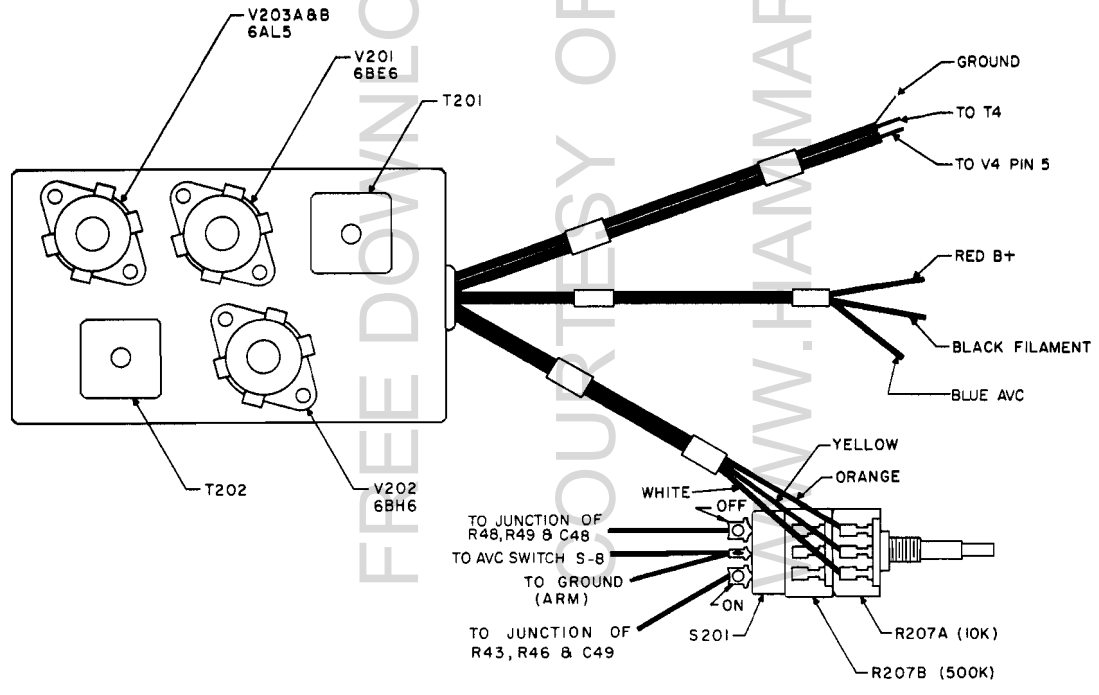

Fig. 6 - I.F. Noise Immunizer as supplied.

PARTS LIST I. F. NOISE IMMUNIZER

Schematic Designation	Description	Hammarlund Part No.
<u>Capacitors</u>		
C201	Fixed, Silver Mica, 5mmf., 500 W. V. D. C.	K23006-8
C202, C203, C204 C207, C208, C209, C212	Fixed, Ceramic Disc, .01 mfd. 600 W. V. D. C.	K23034-19
C205, C210	Fixed, Silver Mica, 150 mmf., 300 W. V. D. C.	K23006-53
C211	Fixed, Silver Mica, 5 mmf., 500 W. V. D. C.	K23006-78
C206	Fixed Ceramic Disc .001, 600 W. V. D. C.	K23034-20
<u>Coils</u>		
L200	Fixed, Inductor, 10 Millihenries	K42336-1
<u>Resistors</u>		
R200	33K ohms, 1 w., 10%	K19310-85
R208	100K ohms, 1 w., 10%	K19310-97
R201	4.7K ohms, 1/2w., 10%	K19309-65
R202	1Kohms, 1/2w., 10%	K19309-49
R203	220 K ohms, 1/2w., 10%	K19309-105
R205	68K ohms, 1/2w., 10%	K19309-93
R206	180 ohms, 1/2w., 5%	K19309-260
R207A	Variable, 10K (Dual Concentric)	K38976-2
R207B	Variable, 500K (Part of R207A)	
R209	27K ohms, 1/2w., 10%	K19309-83
R210	2.2K ohms, 1/2w., 10%	K19309-57
R211	47K ohms, 1/2 w., 10%	K19309-89
<u>Switches</u>		
S201	Switch SPDT (Part of R207A)	
<u>Transformers</u>		
T201	Transformer, 455 kcs.	K38992-1
T202	Transformer, 455 kcs.	K38829-1

FIGURE 3

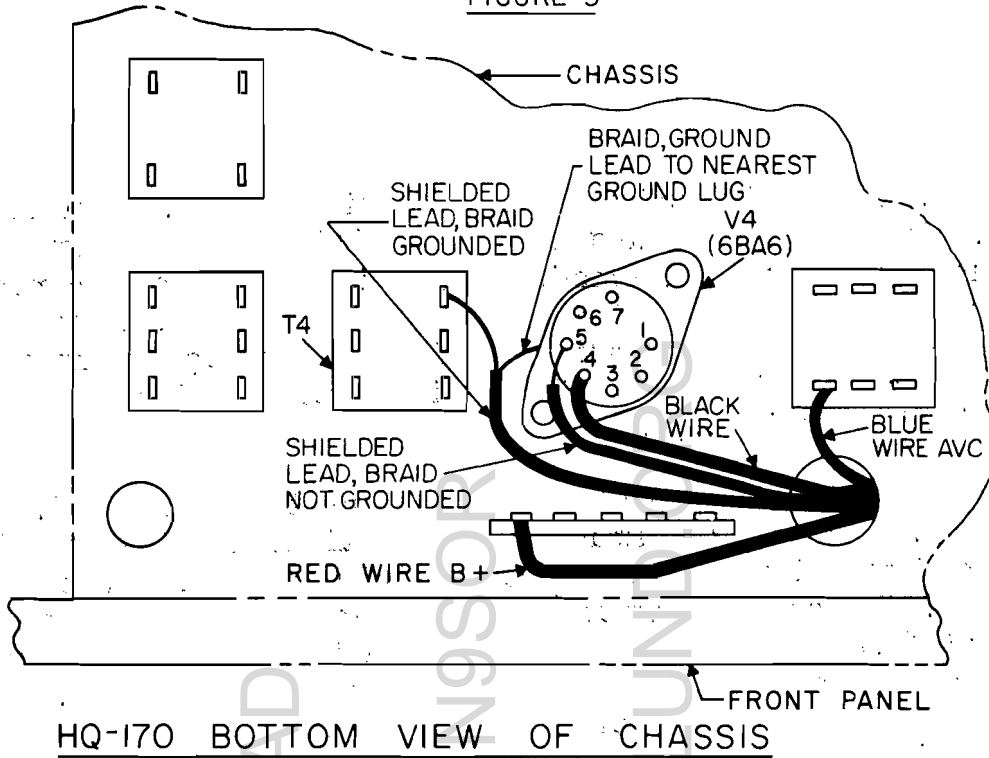
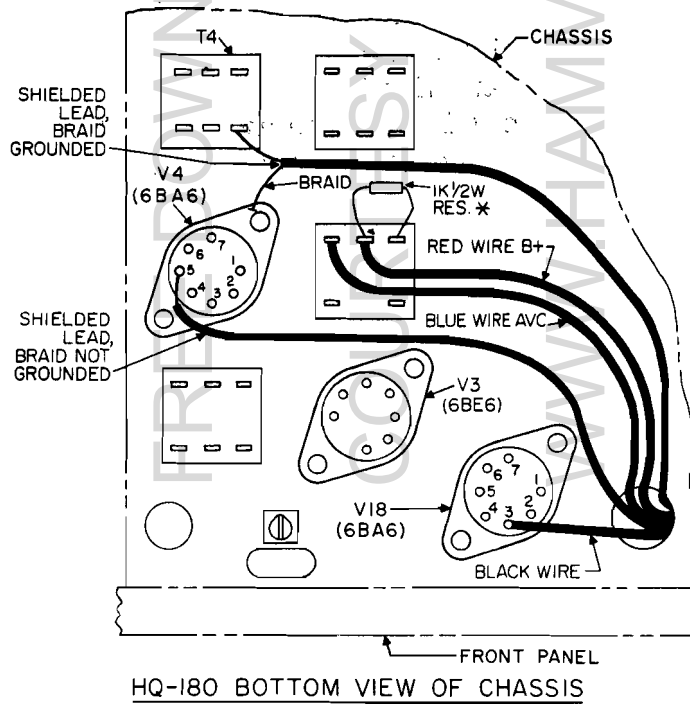

Fig. 3 - HQ-170 Series - Bottom View of Chassis Showing New Connections from I. F. Noise Immunizer.



* ALREADY IN RECEIVER, SHOWN ONLY FOR REFERENCE

Fig. 4 - HQ-180 Series - Bottom View of Chassis, Showing New Connections from I. F. Noise Immunizer.

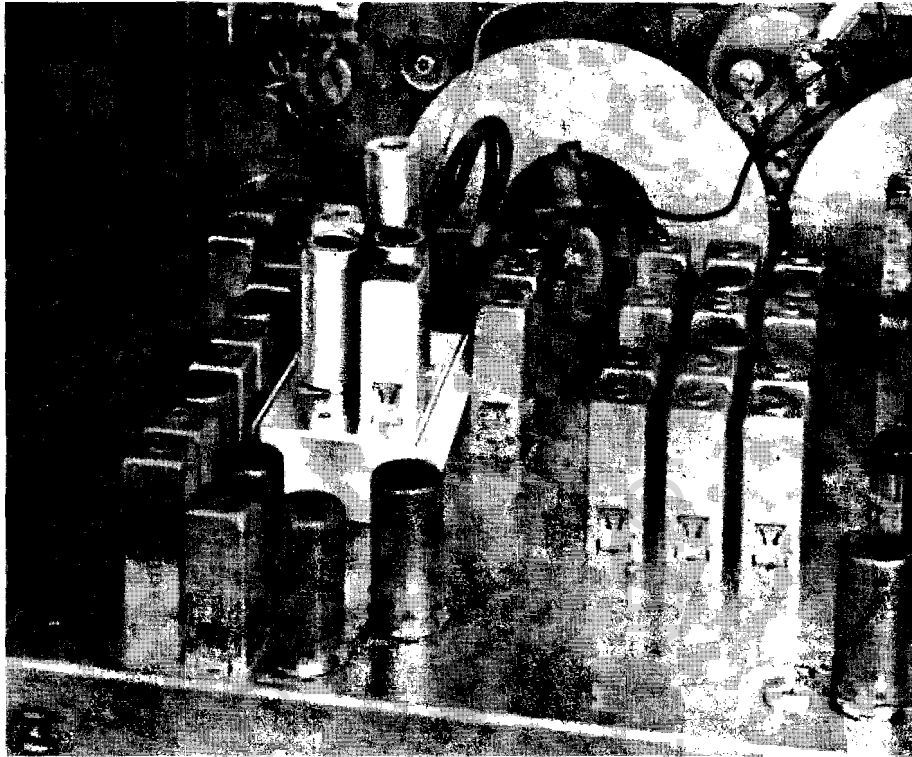

Fig. 1 - Location of I. F. Noise Immunizer in Model HQ-170 Series Receiver

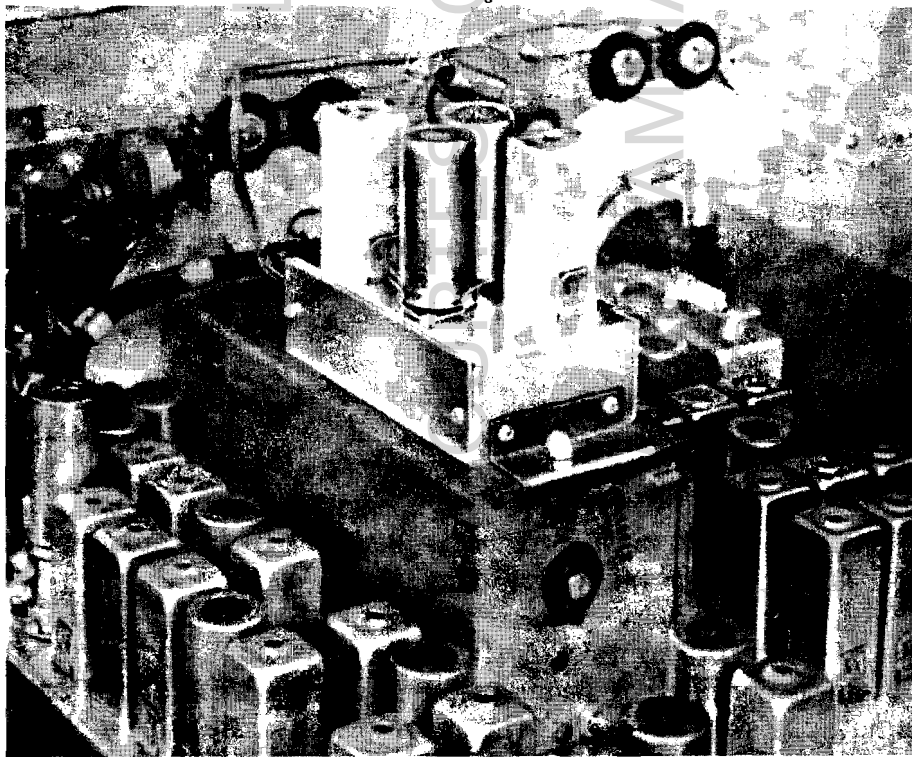

Fig. 2 - Location of I. F. Noise Immunizer in Model HQ-180 Series Receiver

In the Model HQ-170 Series, the Noise Immunizer sub-chassis is fastened to the Receiver chassis by means of the same self-tapping Hex Head screws which are used to fasten the Selectivity-Side Band Switch bracket to the chassis. Loosen the Hex Head self-threading screws sufficiently so that when the Immunizer chassis is placed in its correct position as shown in Fig. 1, it will be flush up against the receiver chassis. Then tighten both screws while firmly pressing the sub-chassis up against receiver chassis.

Loosen set screw on Noise Limiter knob. Remove knob. Remove 3/8" Hex Nut on Noise Limiter control and push shaft through hole. Place 3/8" Lockwasher on new concentric control shaft and insert into panel. Fasten control to front panel with 3/8" Hex Nut. Unsolder wires individually from old control and re-solder to the new control (rear section with switch) in exactly the same position as on the old control as in Fig. 5.

Insert inner and outer shaft knobs onto Noise Immunizer Control Shafts. Adjust each knob properly and tighten set screw on each knob.

Remove entire lead (in receiver) from pin 5 of V4 going to T4. Insert all Noise Immunizer wires through large hole directly below the AM-CW-SSB switch and connect to the proper lugs on strip and tube socket as shown in Fig. 3.

INSTALLATION PROCEDURE FOR MODEL HQ-180 SERIES

In the Model HQ-180 Series, the Noise Immunizer sub-chassis is fastened to the inverted spade lug which is located on the top rear end plate of Bandsread Tuning Gang (right Gang). (See Fig. 2) First, fasten the adapter bracket to the Noise Immunizer sub-chassis with the two 4/40 x 1/4" lg. thread cutting screws. Then, remove the Pal-Nut located on the Bandsread Tuning Gang rear end plate. Place the Immunizer sub-chassis on top of the capacitor dust cover with the spade lug protruding through Adapter Bracket. Fasten the sub-chassis to the Bandsread Tuning Gang with the Nut supplied.

Loosen set screw on Noise Limiter knob. Remove knob. Remove 3/8" Hex Nut on Noise Limiter control and push shaft through hole.

Place 3/8" Lockwasher on new concentric control shaft and insert into panel. Fasten control to front panel with 3/8" Hex Nut.

Unsolder wires individually from old control and re-solder to the new control (rear section with switch) in exactly the same position as on the old control as shown in Fig. 5.

Remove entire lead (in receiver) from Pin 5 of V4 going to T4. Insert all Noise Immunizer leads through large hole directly below the AM-CW-SSB switch and connect to the proper lug on strip and tube socket as shown in Fig. 4.

Fig. 7 - Schematic I.F. Noise Immunizer

