

T.O. 31R2-4-101-3

HANDBOOK  
OVERHAUL INSTRUCTIONS

**RADIO RECEIVER**

MODEL SP-600-JX-21

(HAMMARLUND)

FREE DOWNLOAD

COURTESY OF NOSOR  
WWW.HAMMARLUND.ORG

PUBLISHED UNDER AUTHORITY OF THE SECRETARY OF THE AIR FORCE

Reproduction for non-military use of the information or illustrations contained in this publication is not permitted without specific approval of the issuing service (BuAer or USAF). The policy for use of Classified Publications is established for the Air Force in AFR 205-1 and for the Navy in Navy Regulations, Article 1509.

**LIST OF REVISED PAGES ISSUED**

**INSERT LATEST REVISED PAGES. DESTROY SUPERSEDED PAGES.**

NOTE: The portion of the text affected by the current revision is indicated by a vertical line in the outer margins of the page.

FREE DOWNLOAD

COURTESY OF N9SOR

WWW.HAMMARLUND.ORG

\*The asterisk indicates pages revised, added or deleted by the current revision.

**ADDITIONAL COPIES OF THIS PUBLICATION MAY BE OBTAINED AS FOLLOWS:**

USAF

USAF ACTIVITIES.—In accordance with Technical Order No. 00-5-2.

NAVY ACTIVITIES.—Submit request to nearest supply point listed below, using form NavAer-140: NASD, Philadelphia, Pa.; NAS, Alameda, Calif.; NAS, Jacksonville, Fla.; NAS, Norfolk, Va.; NAS, San Diego, Calif.; NAS, Seattle, Wash.; ASD, NSC, Guam.

For listing of available material and details of distribution see Naval Aeronautics Publications Index NavAer 00-500.

## TABLE OF CONTENTS

<i>Section</i>	<i>Page</i>
INTRODUCTION .....	1
I DESCRIPTION AND LEADING PARTICULARS .....	1
1-1. General .....	1
1-3. Pertinent Information .....	1
1-5. Difference Data Sheets .....	1
II TEST EQUIPMENT AND SPECIAL TOOLS .....	3
2-1. Test Equipment .....	3
2-3. Special Tools .....	3
III MAINTENANCE BEYOND CAPABILITIES OF FIELD .....	5
3-1. General .....	5
3-5. Specialized Maintenance Procedure .....	5
IV DISMANTLING AND DISASSEMBLY .....	7
4-1. Dismantling .....	7
4-5. Disassembly .....	7
V CLEANING .....	11
5-1. Overall .....	11
5-3. Electrical Parts .....	11
5-5. Mechanical Parts .....	11
5-8. Preservation After Cleaning .....	11
VI INSPECTION .....	11
6-1. General .....	11
6-5. Chassis Assembly Inspection .....	12
6-8. Subassembly Inspection .....	12
6-10. Parts Inspection .....	13
6-31. Service Limits .....	15
VII REPAIR AND REPLACEMENT .....	17
7-1. General .....	17
7-3. Switch Base and Spring Assembly .....	17
7-7. Selectivity Switch .....	17
7-9. Retropicalization .....	17
VIII REASSEMBLY AND TESTING OF SUBASSEMBLIES AND ASSEMBLIES .....	19
8-1. General .....	19
8-3. Reassembly of Tuning Unit Assembly .....	19
8-5. Resoldering and Retropicalization .....	20
8-7. Testing of Subassemblies and Assemblies .....	20
IX REASSEMBLY AND TESTING OF COMPONENTS .....	21
9-1. General .....	21
9-3. Reassembly of Chassis and Tuning Unit Assembly .....	21
9-5. Reassembly of Chassis and Panel Assembly .....	21
9-7. Reassembly of R-f Tuners .....	21
9-9. Reassembly of Plug Connector Assemblies .....	22
9-11. Reassembly of Radio Receiver .....	22
9-13. Testing .....	22
X FINAL REASSEMBLY .....	23
XI INSPECTION, TESTING, AND PACKAGING .....	23
11-1. General .....	23
11-3. Minimum Performance and Test Values .....	23
11-5. Packaging .....	23
XII DIFFERENCE DATA SHEETS .....	23

**LIST OF ILLUSTRATIONS**

<i>Figure</i>		<i>Page</i>
1-1.	Radio Receiver, Model SP-600-JX-21	ii
2-1.	Special Tools to Reassemble R-f Strip Assembly	3
2-2.	Special Tools to Reassemble Tuning Unit Shield Assembly	3
2-3.	Special Tools to Reassemble Turret Rotor Assembly	4
2-4.	Special Tools to Reassemble Gear-train Assembly	4
4-1.	Gear-train Assembly, Exploded View	8

**LIST OF TABLES**

<i>Table</i>		<i>Page</i>
I	Special Tools Required for Overhaul	3
II	Identification of R-f Tuners	22

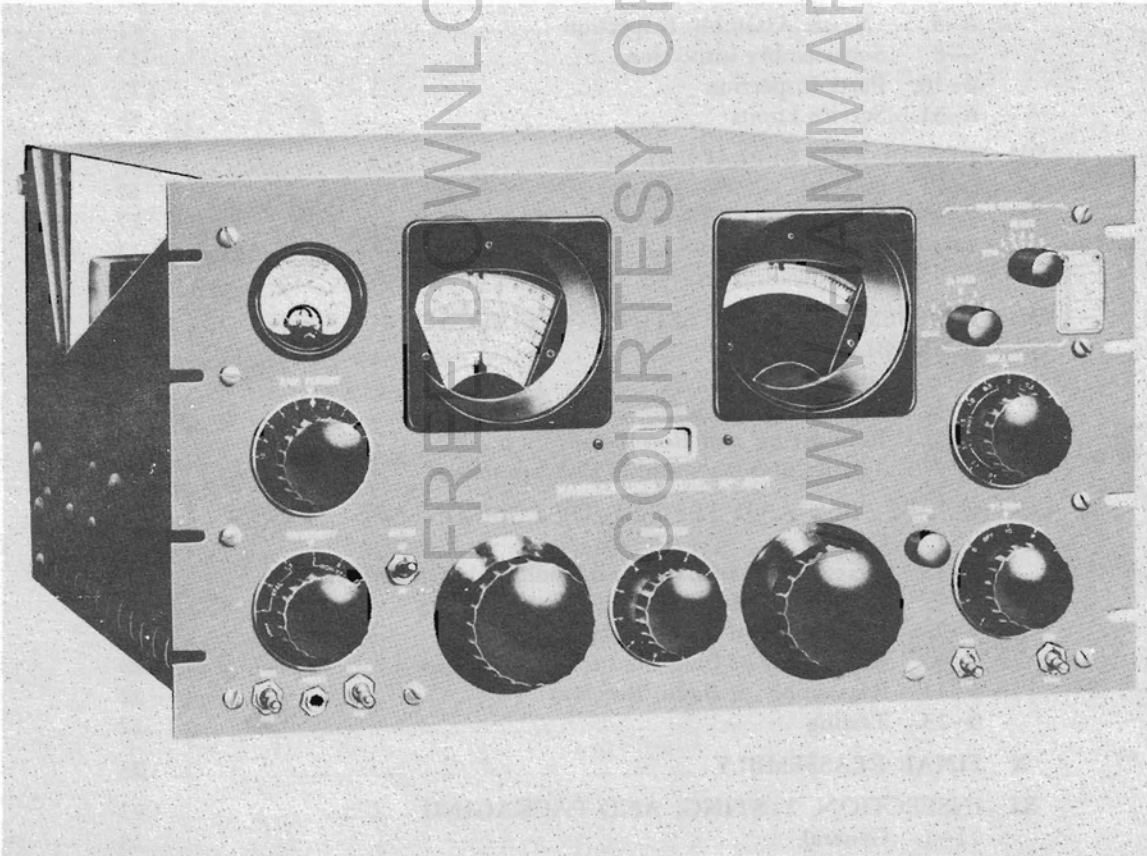

**Figure 1-1. Radio Receiver, Model SP-600-JX-21**

## INTRODUCTION

This handbook has been published to furnish maintenance depot personnel with descriptive information and overhaul instructions for Radio Receiver, Model SP-600-JX-21, manufactured by the Hammarlund Manufacturing Co., Inc., New York 1, N.Y.

The handbook has been prepared in accordance with Specification MIL-H-6814A (ASG). Abbreviations used are in accordance with Air Force-Navy Aeronautical Bulletin No. 261. Electrical and electronic symbols used in the schematic diagrams conform to Standard JAN-STD-15.

For additional information on the radio receiver, the following publications should be consulted:

<i>Title</i>	<i>Publication No.</i>
Handbook Operation Instructions, Radio Receiver, Model SP-600-JX-21	T.O. 31R2-4-101-1
Handbook Service Instructions, Radio Receiver, Model SP-600-JX-21	T.O. 31R2-4-101-2
Illustrated Parts Breakdown, Radio Receiver, Model SP-600-JX-21	T.O. 31R2-4-101-4

## SECTION I

### DESCRIPTION AND LEADING PARTICULARS

#### 1-1. GENERAL.

1-2. This publication comprises overhaul instructions for Radio Receiver, Model SP-600-JX-21 (figure 1-1), manufactured by the Hammarlund Manufacturing Co., Inc., New York 1, N. Y.

#### Note

Refer to the applicable handbook of service instructions for a detailed description and leading particulars of the receiver.

#### 1-3. PERTINENT INFORMATION.

1-4. The receiver r-f coils, r-f chokes, and all soldered connections are treated with fungicidal varnish. All metal parts in contact conform to the electrochemical series so that corrosion is kept to a minimum. In view of the fact

that all possible precautions are taken at the factory to provide each receiver for use in perfect condition, needless unsoldering and replacement of parts during overhaul operations should be avoided.

#### 1-5. DIFFERENCE DATA SHEETS.

1-6. Sections I through XI of this handbook apply to Radio Receiver, Model SP-600-JX-21. Additional models will be covered in Section XII by the use of Difference Data Sheets.

1-7. Overhaul instructions for any models to be included in Section XII will be the same as the procedures given in Sections I through XI, except for the specific differences noted by the applicable Difference Data Sheets.

## SECTION II

## TEST EQUIPMENT AND SPECIAL TOOLS

**2-1. TEST EQUIPMENT.**

2-2. No special test equipment is required to align, adjust, or final test the radio receiver. To facilitate the testing of the receiver a test position should be maintained, provided with the appropriate test equipment and fabricated cables described in the applicable handbook of service instructions.

**2-3. SPECIAL TOOLS.**

2-4. The special overhaul tools required to perform

the work outlined in this publication are listed in table I. The table refers to the figure and index number of the illustration for each tool, the tool part number, and the tool name. The application column in the table briefly denotes the receiver subassembly or parts to which the respective tools are applied when the receiver is overhauled. The manner of use and application of each tool is outlined in detail in paragraphs 7-6 and 8-4.

## TEST I. SPECIAL TOOLS REQUIRED FOR OVERHAUL

Figure & Index No.	Part No.	Nomenclature	Use and Application
2-1(1)	T7982-5	Pin, locating	R-f strip subassembly.
2-1(2)	T7982-6	Bar, line-up	
2-1(3)	T7982-7	Pin, locating	
2-2(1)	T8331-1	Swage	Contact spring and partitions, tuning unit shield.
2-2(2)	T8331-2	Mounting, seat	
2-3(1)	T7644	Jig, fixture	Turret rotor subassembly.
2-3(2)	T8332	Rod	Turret rotor and tuning unit shield, line-up.
2-3(3)	T8333	Wrench, spanner	Turret rotor subassembly nuts.
2-4(1)	T8335	Jig	Band dial location.
2-4(2)	T8334	Pliers	"C" washers, crimping.

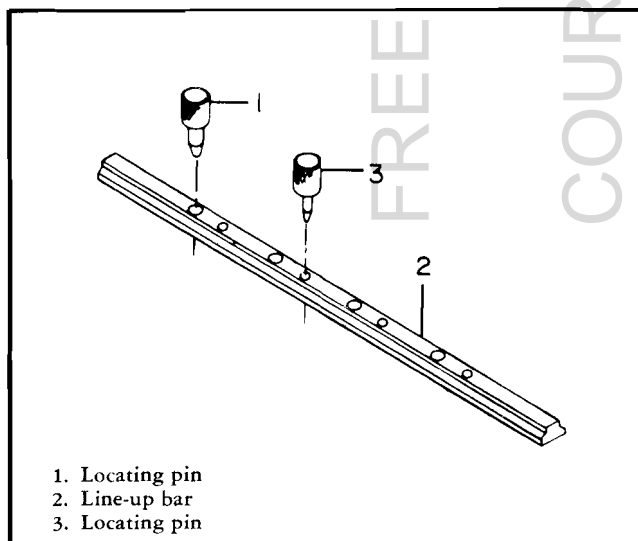

Figure 2-1. Special Tools to Reassemble R-f Strip Assembly

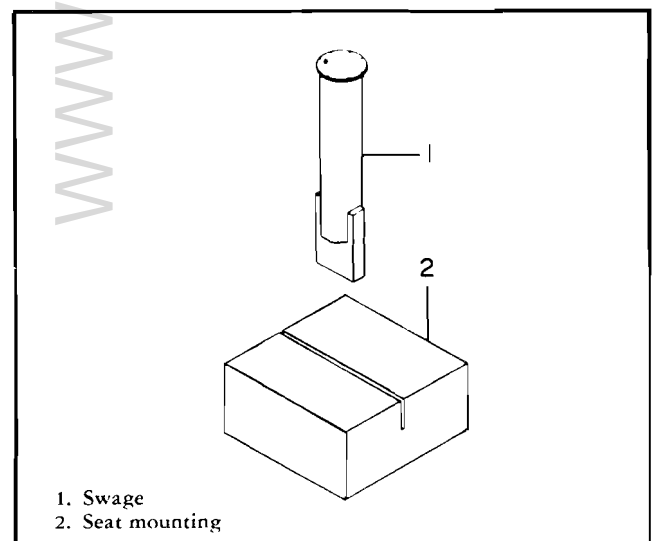
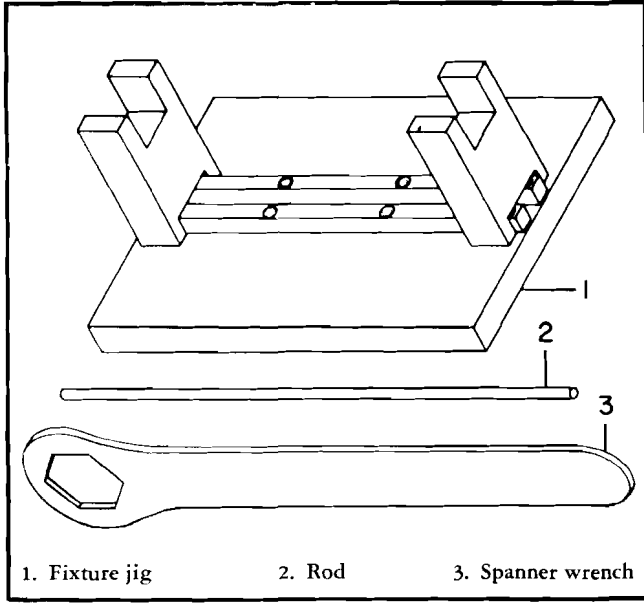
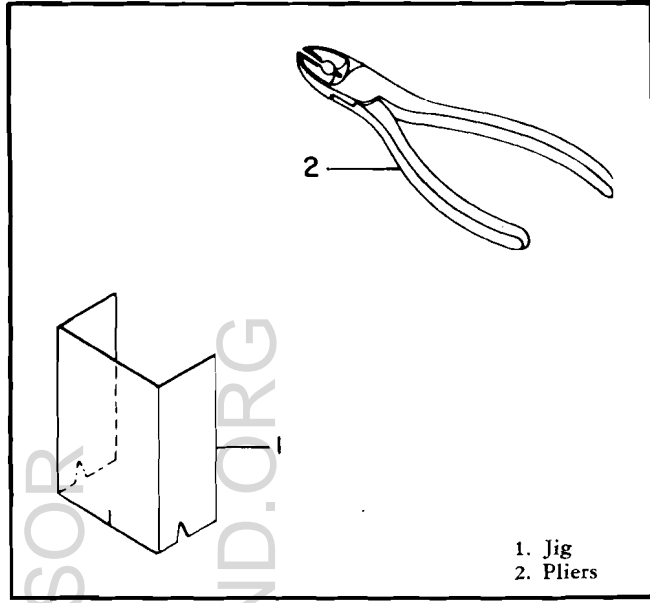

Figure 2-2. Special Tools to Reassemble Tuning Unit Shield Assembly



**Figure 2-3. Special Tools to Reassemble Turret Rotor Assembly**



**Figure 2-4. Special Tools to Reassemble Gear-train Assembly**

**SECTION III****MAINTENANCE BEYOND CAPABILITIES OF FIELD****3-1. GENERAL.**

3-2. The specialized maintenance and repair activities within the scope of depot overhaul are based on receiver trouble-shooting procedures supplementary to those provided in the applicable handbook of service instructions. The data are useful in the step-by-step procedures used to determine specific circuit failures.

3-3. Before resorting to the specialized maintenance and repair procedures, ascertain whether the receiver fault is due to any of the following causes:

- a. Damage or miswiring.
- b. Short circuits between parts or to ground, prior or subsequent to the reassembly of the subassembly or part to the receiver.
- c. Faulty parts whose fault is only evident when the part has been allowed to warm up by turning the receiver on.

3-4. All of the receiver circuitry, apart from that contained in the r-f strip, is accessible. When the receiver fault is isolated to the r-f strip, the subassembly must be removed from the receiver for repair or replacement. To determine the specific cause of the r-f strip failure requires part-by-part analysis to isolate the faulty part. The r-f strip removed for repairs may be externally reconnected to the receiver through means of insulated test clip leads, to render accessible its circuitry for purposes of analysis. When this is done, do not attempt to reconnect the four-gang variable tuning capacitor unless it too is external to the receiver. The r-f tuners for the frequency band desired may be seated in the r-f strip statite base "V" contacts.

**WARNING**

Keep the receiver turned off when externally reconnecting the r-f strip to the receiver.

**3-5. SPECIALIZED MAINTENANCE PROCEDURE.**

3-6. The specialized maintenance procedure outlined in each of the following categories differs from that outlined in the handbook of service instructions. The extent of difference is that the parts in subassemblies are all analyzed while contained in the receiver which is turned on and allowed a warm-up period of at least five minutes.

3-7. **RESISTOR FAILURE.** To determine whether a resistor is normal, determine first its circuit function, noting whether it is isolated or whether it has a d-c

voltage drop across it. If the former, determine first, utilizing a volt-ohmmeter, that it has no d-c voltage across it, possibly due to the failure of its associated isolating capacitor, and then measure its resistance. Turn the receiver off to measure the resistance of any resistor. To measure the resistance of resistors R32, R33, R48, R53, R60, R61, R66, R68, R93, R94, R95, R96, R97, R111, and R112, unsolder one resistor lead to isolate the resistor from the resistor network of which it is part.

3-8. **CAPACITOR FAILURE.** To determine whether a capacitor is abnormal, i.e. open, shorted, or leaky, determine first its circuit function, noting whether it is used for d-c voltage isolating or filtering purposes, for tuning purposes, or to provide a low-impedance series or shunt path for the signal itself.

3-9. **OPEN CAPACITOR.** An open capacitor cannot provide a low-impedance path for the signal, be used to tune a circuit to resonance, or cannot provide filtering action. However, it will keep a circuit isolated. In the isolating instance, the capacitor usually carries the signal or other a-c voltages across it so that an open capacitor can always be analyzed with regard to its circuit function. To do this, apply an appropriate signal to the applicable test point so that the capacitor under consideration, if normal, may perform its function; utilize an a-c vacuum-tube voltmeter or a cathode-ray oscilloscope indication to determine whether the capacitor is open. Each of the following circuit indications, as applicable, provides for checking an open capacitor.

- a. When the capacitor is in series with the signal path of the receiver, but open, its input signal indication is much higher than its output signal indication, to ground in each instance.

- b. When the capacitor provides a return path to ground for the signal, but is open, its ungrounded terminal is at an a-c voltage level above ground.

- c. When the capacitor is used to tune a circuit to resonance, but is open, the circuit inductance cannot be adjusted for resonance.

- d. When the capacitor is used to provide audio filtering action, but is open, its ungrounded terminal will provide indication of excessive ripple, as compared to when the open capacitor is shunted by a normal capacitor.

- e. When the capacitor is used to provide decoupling action in r-f circuits, but is open, more signal indication may be observed across its terminals, as compared to when the open decoupling capacitor is shunted by a normal capacitor.

3-10. **SHORTED CAPACITOR.** A shorted capacitor may be rapidly identified because it cannot have a d-c

or a-c voltage drop between its terminals. Each of the following circuit indications, as applicable, provides for checking a shorted capacitor.

a. When the capacitor circuit connection is such that one of its terminals is normally at some d-c voltage above ground, it cannot provide a d-c voltage indication to ground when a volt-ohmmeter or d-c vacuum-tube voltmeter is used to make the test.

b. When the capacitor circuit connection is such that only an a-c voltage is normally effective at its terminals, possibly due to the signal, and the capacitor is shorted, no vacuum-tube voltmeter or oscillograph indication across the capacitor results. In this instance, the signal usually is not evident in the receiver circuitry immediately following the capacitor.

c. When the capacitor is used as a trimmer capacitor, and is shorted, it has no trimmer effect on tuned circuits. In this instance and when the capacitor is used to provide for the parallel resonance of adjustable core tuned circuits, the signal is usually no longer evident in the subsequent receiver circuitry.

d. When the capacitor is shunted by a resistor as is the case in certain of the r-f tuners, and it is suspected that the capacitor is shorted, the shunted resistor, measured for resistance as outlined in paragraph 3-7, will determine whether the capacitor is shorted.

3-11. LEAKY CAPACITOR. When a capacitor is suspected of being leaky, avoid having to unsolder one of the capacitor terminals from the receiver by utilizing

every possible receiver switch and/or tube means to isolate the capacitor terminal. To determine whether a capacitor is leaky do the following:

a. Turn the receiver off.

b. Adjust the volt-ohmmeter to its highest ohmmeter range and connect it across the capacitor. If the capacitor is good the ohmmeter pointer will flick over slightly and gradually drop back to infinity.

c. Now reverse the test prods. Note that if the ohmmeter deflection is twice that obtained in step b, with the pointer then returning to the position indicating infinite resistance, the capacitor is good. If the pointer does not go back to infinite resistance indication, the capacitor is leaky and should be replaced. This test is not reliable for capacitors whose capacitance value is less than 0.05 uf.

**Note**

When the capacitor is an electrolytic type, one reading will show low resistance and the other much higher. If the higher resistance is not over 100,000 ohms and comparable to that of a spare capacitor, the electrolytic capacitor must be replaced.

Make sure to turn the receiver on at least 15 minutes before making the test so that any electrolytic capacitor dielectric film deterioration may be repaired by subjecting the capacitor to its d-c working voltage. Turn the receiver off, and discharge the capacitor before making a resistance measurement.

**SECTION IV****DISMANTLING AND DISASSEMBLY****4-1. DISMANTLING.****4-2. PRELIMINARY PROCEDURE.**

a. Remove the cartoned radio receiver from its wooden shipping box and then unpack it completely.

b. Dismantle the radio receiver top cover and bottom plate from the receiver chassis and panel assembly.

c. Dismantle the plug connector assemblies, the electron tube complement, the front panel controls, the frequency control unit switch arm and eccentric drive assembly, the front panel assembly, etc from the receiver chassis and panel assembly.

d. Strip the main dial indicator and mounting, both main and vernier dials, both side plates, etc from the receiver chassis and tuning unit assembly.

**4-3. DISMANTLING THE TUNING UNIT ASSEMBLY.** To dismantle the tuning unit assembly from the receiver chassis and tuning unit assembly, use the following step procedure:

a. Unsolder two green/white leads, one each from terminal strips E14 and E17.

b. Unsolder two blue/black leads from second mixer transformer T2.

c. Unsolder white/black, red/white, blue/red, yellow/black, and red/green leads from terminal strip E13.

d. Unsolder two red/green, one green/red, and one yellow/red leads of the main wiring cable from conversion switch S4.

e. Remove two No. 10-32 screws and one stud post assembly, on either side of tuning unit assembly, which screw into nut plate brackets through clearance holes in gear-train plate and chassis proper.

f. Remove one No. 10-32 screw in angle bracket on rear of tuning unit assembly, which passes through clearance hole at back of chassis proper.

g. Lift out the tuning unit assembly.

**4-4.** The tuning unit assembly comprises several sub-assemblies which may be dismantled from it and then separately disassembled. These are the following:

a. The mixer plate coil assembly T1.

b. The r-f wiring assembly, i.e., the r-f strip.

c. The variable capacitor, i.e., the eight section, four-gang tuning capacitor.

d. The gear-train assembly.

e. The 24 r-f subassemblies, i.e., the r-f tuners.

**4-5. DISASSEMBLY.**

**4-6. DISASSEMBLY OF GEAR-TRAIN ASSEMBLY.** The gear-train assembly (figure 4-1) is disassembled in accordance with the following step-by-step procedure.

a. Remove cam and hub assembly (1).

b. Remove slide spring (2), then remove four screws (4) and four spacers (5) and remove the slide and roller assembly (3).

c. Remove two detent springs (6) and lever and roller assembly (7).

d. Remove screw (9) and two screws (10) used to mount bearing plate (8). Then remove cam and hub assembly (11), shaft and gear assembly (12), flywheel and shaft assembly (13), and idler (14).

e. Loosen nut (16) and remove bearing screw (15) and ball bearing (17).

f. Remove two screws (19) and bearing plate (18).

g. Remove three screws (20) and then remove the shaft and gear assembly comprised of hub (21), shaft and gear assembly (23) and retaining ring (22). If required, remove the retaining ring (22) and disassemble the hub (21) from shaft and gear assembly (23).

h. Remove three screws (25) and three posts (24).

i. Remove dial, hub and gear assembly (26), gear and hub assemblies (27 and 28), and main dial hub and gear assembly (29) by removing the associated retaining rings (30). Then remove gear and drive pin assembly (31) and ball bearing (32).

j. Remove two screws (33) and then remove the gear plate assembly comprised of two gears (34), two washers (36), two retaining rings (35), and plate and pin assembly (37).

k. Remove switch spring (38) and lever assembly (39).

l. Remove three screws (42) and three lockwashers (43), and then remove gear (40) and gear (41). Remove three screws (45) and three lockwashers (46), then remove hub (44). Remove wavy washer (47), screw (49), mounting disc and shaft assembly (48), and three contact springs (50).

m. Remove three spider springs (51). Remove two screws (53) and nut plate (52). Remove ten screws (55) and disassemble base plate and spider assembly (54) from tuning unit shield assembly (56).

**4-7. DISASSEMBLY OF CHASSIS.** The chassis assembly may be disassembled in any sequence desired subsequent to the removal of the three-section, four-pole,

1. Cam and hub assembly
2. Slide spring
3. Slide and roller assembly
4. Screw
5. Spacer
6. Detent spring
7. Lever and roller assembly
8. Bearing plate
9. Screw
10. Screw
11. Cam and hub assembly
12. Shaft and gear assembly
13. Flywheel and shaft assembly
14. Idler
15. Bearing screw
16. Nut
17. Ball bearing
18. Bearing plate
19. Screw
20. Screw
21. Hub
22. Retaining ring
23. Shaft and gear assembly
24. Post
25. Screw
26. Dial, hub and gear assembly

27. Gear and hub assembly
28. Gear and hub assembly
29. Main dial hub and gear assembly
30. Retaining ring
31. Gear and drive pin assembly
32. Ball bearing
33. Screw
34. Gear
35. Retaining ring
36. Washer
37. Plate and pin assembly
38. Switch spring
39. Lever assembly
40. Gear
41. Gear
42. Screw
43. Lockwasher
44. Hub
45. Screw

46. Lockwasher
47. Wavy washer
48. Mounting disc and shaft assembly
49. Screw
50. Contact spring
51. Spider spring

52. Nut plate
53. Screw
54. Base plate and spider assembly
55. Screw
56. Tuning unit shield assembly

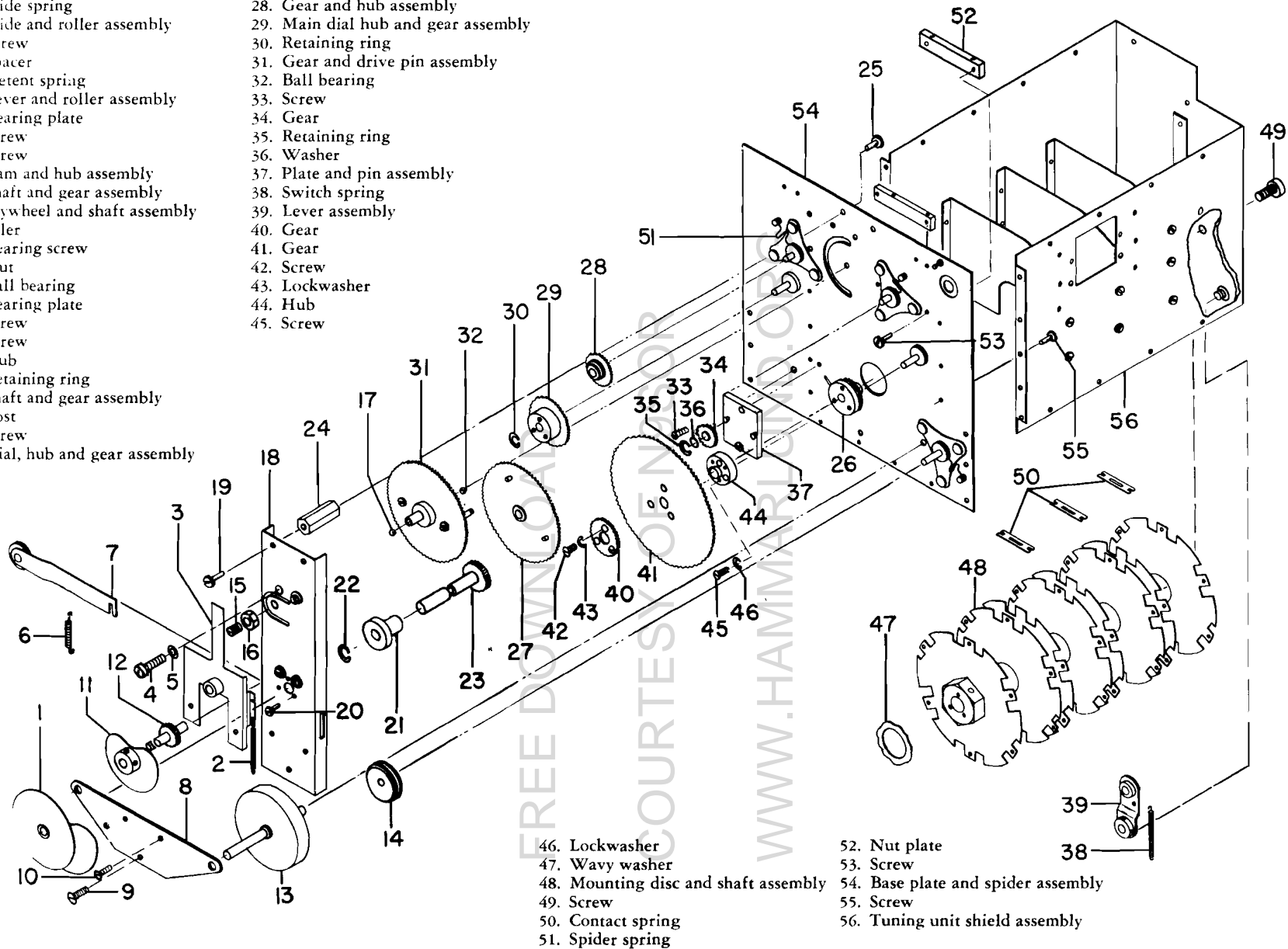

Figure 4-1. Gear-train Assembly, Exploded View

6-position rotary selectivity switch assembly, which is removed first to get at all chassis wiring underneath it. This switch assembly comprises rotary switch S5A, B, C, three resistors, eight insulated electrical wires, five bare electrical wires, and two pieces of vinylite tubing which cover in part two of the bare electrical wires. The switch assembly is removed in preference to removing the rotary switch proper to minimize the unsoldering during removal.

4-8. Certain other subassemblies and parts of the chassis assembly, likewise, may be removed in such a manner as to minimize unsoldering during removal.

These are:

a. The audio output transformer, which is removed with all the electrical wire leads and the one capacitor that are soldered to it.

b. The antenna input socket, which is removed with the black electrical wire that is soldered to it.

c. The meter a-f adjustment potentiometer, which is removed with the electrical wire jumper that is soldered to it.

d. Both the large octal sockets which are removed with the electrical wire leads, resistors, and capacitors that are soldered to them.

4-9. The r-f strip, i.e., the r-f wiring assembly, which is contained in the tuning unit assembly, has its tube sockets removed with the bare electrical wires that are soldered to certain of the tube sockets. Also, the isolantite switch bases of the r-f strip are removed with the bare electrical wires, certain resistors, and certain capacitors soldered to them, which do not interfere with the removal.

4-10. The frequency control unit and the audio filter assembly, which are contained in the chassis and panel assembly of the receiver, may be dismantled from the receiver at any stage in the overall disassembly procedure outlined. The frequency control unit socket and selector switch are disassembled by unsoldering the bare electrical wire leads soldered to them from the socket and switch contact terminals; also, the bare electrical wire common to the six crystal sockets is unsoldered subsequent to the removal of the crystal socket plate carrying the crystal sockets. The audio filter assembly is disassembled subsequent to its dismantling as a unit.

FREE DOWNLOAD  
COURTESY OF NSASOR  
WWW.HAMMARLU.COM

## SECTION V

### CLEANING

#### 5-1. OVERALL.

5-2. Clean the radio receiver by blowing out with dry, filtered compressed air at a pressure of approximately 100 psi. Accessible parts may be wiped with a clean cloth or dusted with a small dry brush.

#### 5-3. ELECTRICAL PARTS.

5-4. When the radio receiver is dismantled and its subassemblies are disassembled, blow out, wipe, and dust all wired electrical parts as outlined in paragraph 5-2 for the overall receiver. The air pressure at the subassembly or part may be decreased by increasing the distance between the air nozzle and the work.

### WARNING

Wear goggles to protect eyes from dust.

#### 5-5. MECHANICAL PARTS.

5-6. Clean all mechanical parts such as the chassis, side plates, shields, screws, etc by brushing with cleaning

solvent, Federal Specification P-S-661, or trichlorethylene, Specification MIL-T-7003. To remove corrosion use No. 000 sandpaper as well, then wipe with a clean cloth.

5-7. Dirty gears are cleaned best with a pipe cleaner or small brush dipped in any one of the cleaning fluids mentioned in paragraph 5-6. The variable air trimmer capacitors may be cleaned by soaking them bodily in trichlorethylene, and then blowing them out. This applies to the r-f trimmer capacitors even when assembled to their isolantite bases, with r-f coils, resistors, and all other fixed capacitors removed.

#### 5-8. PRESERVATION AFTER CLEANING.

5-9. R-F COILS AND CHOKES. Treat all r-f coils and chokes used in the radio receiver by dipping in bakelite resin, fungicidal varnish conforming to Specification MIL-V-173.

5-10. FOUR-GANG VARIABLE AIR CAPACITOR. The four-gang variable air capacitor end bearings are lubricated at the factory with lubricating grease, Specification MIL-L-7711. Relubricate in the remote instance when the need arises.

## SECTION VI

### INSPECTION

#### 6-1. GENERAL.

6-2. The radio receiver is inspected by careful observation and feel for any possible abnormal physical indication. Even though a mechanical defect appears trivial, it must be repaired at the first opportunity so that it does not develop cumulative receiver abnormalities leading to serious failure. Periodic receiver overhaul provides an opportunity for qualified inspection personnel to determine the need for immediate repair of the receiver.

6-3. INSPECTION TECHNIQUE. To properly inspect each radio receiver, the inspector must thoroughly familiarize himself with the receiver as follows:

a. Determine first the normal appearance of the radio receiver by carefully noting the appearance of each subassembly and part and their assembled inter-relationship as outlined in paragraphs 4-1 through 4-10 and 8-1 through 8-6. Until such time that the normal detailed ap-

pearance of the receiver is committed to memory, compare the receiver part by part with a receiver known to be in the condition in which it left the factory. Carefully observe the color and finish of all parts, their relative placement, the dress of each electrical wire, the quality of the crimping of each soldered wire, the amount of solder used to make a soldered joint, and the manner and location of those soldered joints providing electrical grounds. Note that all soldered joints, all r-f coil assemblies, and all r-f chokes are tropicalized as evidenced by their brownish fungicidal varnish coating. Note that the 8 nuts at the 2 escutcheons on the front panel, the 12 nuts at the 6 crystal sockets on the frequency control unit, the bearing screw (5, figure 4-1), and each nut used to mount each pin on each of the 24 r-f tuner subassemblies is coated with varnish. The varnish is used as an aid to secure each nut since not too much strain can be used to tighten each assembly.

b. Determine next the manner in which the receiver operating controls activate the mechanical means used to perform each control function. Get the feel of each control and commit it to memory. Note that the tuning control is flywheel balanced and that it is free to turn even when the tuning lock is locked. Note that the two indicators for the main dial and the one indicator for the vernier dial all simultaneously present zero dial indications when the four-gang variable air capacitor is fully meshed. Note that the movable main dial frequency indicator pointer locates at the frequency scale on the main dial corresponding to the frequency band indented and whose frequency range is that shown on the dial visible through the small window contained in the front panel. Note the manner in which the frequency control unit crystal switch arm and eccentric drive assembly drives the two switches coupled to the drive assembly, the orientation of the drive arm and the effect of the small helical spring used. Note the spring-return action of the meter switch. Note the extent to which the gears (34, figure 4-1) mesh with those they engage and the hole provision in the bearing plate (8) to get at one of the screws (33). Note that the lubrication used on the gear-train assembly is barely visible. Note, by feel, the tightness of the adjustable tuning cores and trimmer capacitors, but make sure not to disturb their adjustment settings.

6-4. RECEIVER ABNORMALITIES. Inspect the receiver with regard to each of the following possible categories of abnormality:

a. Aging: Aging of the receiver is indicated by non-positive operation of movable parts whose normal function during movement or when indented is controlled through the use of springs, cams, gears, ball bearings, or precise bearing fits to trued machined shafting.

b. Burning: Overheating of the receiver is indicated when parts comprising it show discoloration, blistering, bulging, or smell burnt.

c. Leakage: Evidence of oil or insulating compound at the terminals of sealed-container parts provide the earliest possible evidence of receiver leakage. The leakage may be evident too at pin holes and/or breaks in the container itself.

d. Corrosion: Evidence of receiver corrosion is the oxidation (rust) which forms on surfaces, screws, nuts, etc, usually where different metal areas are in contact.

e. Dust, dirt, etc: The need for cleaning the receiver is evaluated best by noting the extent to which dust, dirt, etc has accumulated at electron tube socket terminals, resistor boards, and other not too easily accessible soldered joints and corners in the receiver.

f. Looseness: The need for tightening any sub-assembly or part comprising the receiver is evaluated by checking the suspected part for tightness. When checking attaching hardware such as nuts and/or screws, consider the assembly tight when no more than a 90-degree turn may be taken up in the attaching part. Make sure to reseal those nuts listed in paragraph 6-3 whenever occasion arises to tighten any one of them.

## 6-5. CHASSIS ASSEMBLY INSPECTION.

6-6. OVERALL: Apart from the careful inspection of the radio receiver for physical damage evident by observation, the receiver controls should all be tried to see that they function properly. Then inspect the receiver chassis assembly for the following conditions:

a. Switch the selectivity switch from position to position and inspect each switch contact for evidence of charring of the bakelite switch wafers; if charred, replace the switch.

b. Check at all tube socket terminals for possible arcing and charring between terminals; if charred, replace the tube socket concerned. To look at the tube sockets on the r-f strip, remove the r-f coil assemblies, and use a small dental mirror.

c. Check the conversion switch contacts for possible arcing and charring between contacts; if charred, replace the switch.

6-7. SWITCH BASE AND SPRING ASSEMBLY. Remove the 20 r-f tuner subassemblies on five of the six receiver frequency bands, doing this with the receiver chassis and panel assembly turned upside down. Engage the pin contacts of the four r-f tuner subassemblies kept in the tuning unit assembly with the "V" switch contacts assembled to the isolantite bases contained in the r-f strip, using the band change control on the front panel. Note that the "V" switch contacts are spread by the pin contacts and that the pin contacts center up in the "V" switch contacts; also check to see that none of the "V" switch contacts are broken, and that the pin contacts in the 24 r-f tuner subassemblies are not loose. Replace any broken "V" switch contacts and tighten any loose pin contacts, as outlined in paragraph 7-5.

## 6-8. SUBASSEMBLY INSPECTION.

6-9. For purposes of receiver overhaul, inspect each subassembly removed from the receiver, following the procedures outlined below, as applicable.

a. Check the dress of each part, such as capacitors, resistors, coils, chokes, terminal boards, and the electrical wire lead lengths used. Check the clearance between parts and their mountings, the encoded values and tolerances of resistors and capacitors; also check the part numbers of coils, r-f tuner subassemblies, and the reference symbol circuit designations on transformer shield assemblies, etc.

b. Check the quality of each soldered joint and the location and manner of making each specific subassembly ground connection.

c. Check the tightness of staked terminals, screws, nuts, clamps, and all parts comprising the subassembly. Check each spring for resilience and proper length, curvature, etc. Check adjustable tuning cores for proper operation and, if bent, note the extent to which the tuning core enters the coil it tunes, so that it may be so readjusted prior to reassembly, thereby not necessitating too much of an adjustment during the subsequent alignment.

d. Shake out loose metal and other particles. Make sure none remain wedged in the assembly. Look closely for metal or other foreign matter, especially between the stator and rotor plates of the variable air trimmer capacitors. Mesh all trimmer capacitors, checking for even meshing and spacing between plates.

e. Carefully check bakelite and melamine boards for scratches and cracks; make sure isolantite bases, insulator feed-throughs, and crystal porcelain holders are not minutely cracked or chipped.

f. Check multiple coil assemblies mounted on the same form for spacing. Make sure the start and finish leads on all coil assemblies are properly connected. Check each coil for continuity and for broken strands. Check for nicks or scratches on coils and chokes, also check to see that the fungicidal varnish coating is not punctured.

g. Check the possibility of the parts of the sub-assembly shorting to other subassemblies or to the receiver chassis, when assembled. Make sure the pilot lamps, meter board, etc mount rigidly.

h. Check to see that the metal finish on each of the plated parts contained in the subassembly has the proper finish. Check to see that any excessive fraying of wire insulation is cut off and touched up with insulation compound (varnish), Specification MIL-C-13811.

#### 6-10. PARTS INSPECTION.

6-11. For purposes of receiver overhaul, each part contained in the receiver, when removed, may be inspected in accordance with the applicable procedures outlined below. When a part fails to meet any one of the considerations listed for it, reject it; but in instances where the part only requires cleaning have it cleaned prior to reinspection. All repaired parts must be reinspected prior to use.

6-12. ELECTRON TUBE INSPECTION. To inspect each of the electron tubes in the receiver, remove the tube shield, if any, and in the instance of two of the tubes remove the top-hat type of tube retainer associated with each.

a. Check the firmness of each tube in its socket. Press the tube into the socket, exerting only normal pressure. When the tube is properly seated it should be held firmly in place, as evidenced by feel.

b. Let the tubes cool off before removing them from their sockets in the receiver. Use the appropriate tube remover to remove miniature tubes; also, straighten the miniature tube pins in the appropriate pin straightener before trying to insert the miniature tube into its socket. When inserting the miniature tube do so with the top of the tube socket visible so that the tube pins may be properly aligned in relation to the socket.

c. Inspect the glass envelope of each tube for dirt; also check to see that the tube envelope is not loose. Make sure that miniature tube pins are not loose or broken, being careful not to bend the pins during removal or insertion of the miniature tube. Check to see that the glass envelope is not chipped at the pins.

6-13. RESISTOR INSPECTION. Apart from the vitreous-enameled bleeder resistors R85, R72, and R73 in the B+ rectifier supply, which are of the usual lug type and rated respectively at 10, 20, and 20 watts, all the resistors in the receiver are of the pigtail, fixed composition insulated type, rated at 1/2, 1/3 or 1 watt.

a. Inspect the coatings of R85, R72, and R73 for signs of cracking and chipping, especially at the ends of each.

b. Examine the body of each resistor for blistering, discoloration, and breaks caused by overheating.

c. Inspect all resistor leads for dirt, dust, corrosion, and looseness. Check the security of all mountings. Once a resistor of the pigtail type is unsoldered, do not re-use if the leads were initially cut short since the point of entry of the lead may be partially or completely broken. Also, the heat applied during unsoldering and resoldering may damage the resistor or change its value.

#### 6-14. AIR-DIELECTRIC VARIABLE CAPACITOR INSPECTION.

a. Inspect the capacitor for dust, dirt, lint, and poor or broken soldering.

b. Inspect the capacitor plates for visible damage such as nicks and bending. Also, by meshing the rotor and stator plates, make sure that during meshing the plates do not touch and that they remain reasonably centered at all times with regard to plate spacing.

#### CAUTION

Never tamper with the plates of the main tuning capacitor.

c. Inspect the capacitor plate mountings, terminals, and overall for looseness, wear, breaks, or other damage. Make sure that the main capacitor ball bearings and the trimmer capacitor rotor spring assembly in each instance provide for smooth, firm rotor and stator meshing.

#### 6-15. PIGTAIL-LEAD CAPACITOR INSPECTION.

a. Inspect each pigtail-lead type capacitor for lead looseness. Do this by applying a firm steady pull to each capacitor lead in turn, making sure that the tension applied is not excessive.

b. Inspect each capacitor for discoloration, breaks, chipping, and evidence that the molded casing does not completely enclose the capacitor assembly.

c. Inspect the three oil-filled, tubular, metal-case capacitors (C137, C144, and C163) for evidence of oil leakage at the pigtail-lead solder terminal connections, for the quality of the solder terminals, and for corrosion.

#### 6-16. TERMINAL-TYPE CAPACITOR INSPECTION.

a. Inspect the capacitor terminals for insulation cracks, looseness, corrosion, and evidence of leakage of electrolyte in the case of dry electrolytic capacitors.

b. Inspect the metal case container of each unit for bulges, dents, cracks, and other damage of any kind. Make sure the terminal lugs on the three-section electrolytic capacitor (C161A, B, C) are not loose.

## Paragraphs 6-17 to 6-23

6-17. FUSE INSPECTION. The fuse complement of the radio receiver comprises two holder type fuses. One is of the slow blow "Fusetron" type rated at 1.6 amperes and the other is of the instantaneous type rated at 3/8 ampere. Throw blown fuses away.

a. Inspect each fuse for loose ends and cracks or breaks in their glass encasings.

b. Inspect each fuse holder and holder cap for evidence of burning, charring, corrosion, and dirt; make sure the spring tension in the fuse holder is strong enough to butt the fuse up against the back of the fuse cap, noting that the cap spring tension only provides for holding the fuse to the cap for insertion or removal.

6-18. INSULATOR INSPECTION. The two insulators used in the radio receiver are of the feed-through type. That on the frequency control unit is made of steatite and has a white glazed finish while that on the r-f strip is made of white isolantite.

a. Inspect the steatite and isolantite insulators for the possible deposit of foreign matter since an insulator is only as good as the condition of its surface.

b. Inspect the steatite and isolantite insulators for fine-line surface cracks where moisture and dust will accumulate and form a leakage path. Make sure these insulators are clean, without cracks, or chips, and that the quality of the soldering and spinning used for mounting is good.

6-19. SWITCH INSPECTION. The switch complement of the radio receiver comprises switches of both the enclosed and open types.

a. Inspect the mechanical action of each switch and look for dirt, dust, and corrosion on all exposed parts. In the instance of enclosed switches, check the action of the switch by actuating the control knob or toggle. In the instance of the spring-return meter switch, note the amount of pressure needed to overcome the spring tension. In the instance of the crystal selector switch, make sure that the detent action is positive acting and that the front panel control knob activates the frequency control switch contained in the frequency control unit in each of its eight positions but only activates switch S3 on the base plate in its two most counterclockwise positions.

b. Inspect the switch base and spring assembly, covered in paragraph 6-7, and the three-section selectivity switch contacts for looseness, dust, dirt, and corrosion. Make sure that the rotors of each switch make contact with the stators as evidenced by the visible spreading of the stator contacts when engaged by the rotors. Do not pry the leaves of the stator contacts apart in any manner whatsoever, other than by the the engagement of the switch rotors themselves.

6-20. R-F COIL AND CHOKE INSPECTION. Apart from the r-f coil or transformer contained in each of the 24 r-f tuner subassemblies, the radio receiver has an i-f output autotransformer, 11 r-f chokes, and 15 r-f transformers or coils, the latter contained in the various transformer subassemblies comprising the receiver. Four

of the latter, contained in the first and second i-f transformers, are each contained in two iron cups for purposes of shielding. No attempt should be made to remove said iron cups; the coil assembly itself is to be replaced whenever the need for the replacement of these r-f coils arises.

a. Inspect each r-f coil, r-f choke, and shielded r-f coil for cleanliness, the quality of soldering, the firmness of terminals, coil turns, and the assembly, and fungicidal varnishing, as applicable. Make sure that there are no nicks or cracks in the coil forms or in the fungicidal varnish coating of each coil. Remember that the coil form functions as a high-voltage insulator whose requirement is the utmost in cleanliness.

b. Inspect each r-f coil and r-f choke for the continuity of each winding. Check the d-c resistance of each winding as tabulated in the applicable handbook of service instructions. Note that the secondaries of the three r-f coils in the r-f tuner subassemblies used on the 1.35-3.45 mc frequency band of the receiver and the four iron-cup-shielded i-f coils each use No. 15/44 litz wire. In all other applicable instances No. 7/41 litz wire is used.

6-21. POTENTIOMETERS. The radio receiver utilizes potentiometers as r-f gain, audio gain, bfo injection, a-f meter adjustment and r-f meter adjustment controls.

a. Inspect the metallic parts of each control for dust, dirt, and evidence of corrosion. Make sure that the unit has no mechanical defects such as loose terminal lugs, loose body assembly, or a loosely keyed shaft.

b. Inspect the insulated body of the unit for cracks and chipping.

c. Inspect the operation of the control, making sure that the shaft turns smoothly but firmly in its mounting.

6-22. TERMINAL BOARDS. The radio receiver utilizes 19 terminal boards for purposes of part mounting.

a. Inspect the mechanical assembly of each terminal board for loose brackets, terminals, eyelets, rivets, etc.

b. Inspect the terminal board bakelite or melamine insulation for cracks, breaks, dirt, charring, or breakdown of the insulation due to the corrosion of the metal parts of the terminal board assembly.

6-23. CABLES. The main wiring cable is pre-fabricated before assembly to the receiver chassis and comprises, apart from numerous electric wires, five shielded insulated leads.

a. Inspect the insulation of each visible electrical wire and cable contained in the main wiring cable, and that of the shielded lead cables, noting whether the insulation is cracked, deteriorated, cut, kinked, or strained.

b. Inspect each end of each lead for broken strands, fraying of the insulation, and damage due to poor soldering and crimping. Make sure that partially or completely broken strands are not hidden by the insulation.

c. Inspect to see that the braided shield of all the shielded insulated leads does not short to the shielded conductor.

6-24. **CONNECTORS, PLUGS, AND SOCKETS.** The antenna input and the i-f output connectors, the phones jack, and the 6 crystal and 20 electron tube sockets comprise the connector and socket complement of the receiver.

- a. Inspect the insulation of each for dirt, dust, corrosion, charring, and cracks.
- b. Inspect contacts for collected dust, corrosion, breaks, and other than normal looseness.
- c. Inspect each connector and socket, checking the contact provided when its complementary plug, crystal, or tube is inserted. Increase, when needed, the spring tension of the phones jack. When a tube socket has replaceable contacts which require replacement, replacing the contacts may prove more practical than replacing the tube socket.

6-25. **METER.** The tuning meter contained on the front panel of the receiver has a 200-microampere d-c movement and is provided with two scales.

- a. Inspect the meter for cracked or broken cover glass, dents in the case, a warped dial, and a bent or broken pointer.
- b. Inspect the meter for dust, dirt, and corrosion on the meter case and terminals. Remove the meter cover and repeat the inspection for the inside of the meter cover and the meter proper.
- c. Inspect, by checking the meter adjustment screw, to see that the pointer may be properly set to the initial dial indication from either direction. Make sure that the adjustment spring is not caught on the adjustment arm.
- d. Test the meter for balance by incorporating it in a circuit such that it will indicate +20 db on the r-f scale at 88 microamperes  $\pm 5$  percent, and will repeat this indication.

6-26. **CRYSTALS.** The 3.5 mc oscillator crystal and the 455 kc i-f filter crystal, apart from any specially ordered h-f-o crystals used for fixed-frequency crystal-controlled operation, comprise the crystal complement of the receiver.

- a. Inspect each crystal for dust, dirt, cracks, breaks, and corrosion.
- b. Inspect the 455 kc crystal terminals, to which are soldered pigtail-type leads, and the 3.5 mc oscillator crystal flat strip terminals, to make sure that they are tight. Also inspect the quality of the pigtail lead soldering in the instance of the former and the terminal silver plating of both. Make sure that the cover spring retainer for the 3.5 mc oscillator crystal provides sufficient tension to firmly seat itself.
- c. Inspect the h-f-o crystals for dust, dirt, dents, poor soldering of metal case, corrosion of case and pin terminals, cracked terminal pin insulation, and loose terminal pins. These type CR-18/U crystals conform to Specification MIL-C-3098, but have stamped on the top and one side the signal frequency in kc for which they are intended.

6-27. **TRANSFORMERS AND CHOKES.** The receiver audio output and power transformers and the two B+ rectifier filter chokes are all cased similarly. The power transformer is oil impregnated and hermetically sealed. The audio transformer is oil filled. The two filter chokes are hermetically sealed.

- a. Inspect for blistering, bulging, or leakage from containers and from terminals.
- b. Inspect for broken, cracked, or charred insulation at the terminals. Inspect to make sure terminals are not loose.
- c. Inspect for dust, dirt, lint, or foreign material between terminals since same will absorb moisture which in time provides a leakage path for high voltage breakdown between terminals.

6-28. **FUNCTIONAL MECHANICAL PARTS.** The mechanical parts such as coupling shafts, couplings, drive arm and eccentrics, gears, lever and roller, dials, cams, control knob and dial assemblies, springs, etc, which provide for the proper mechanical functioning of the receiver, all require inspection.

- a. Inspect for dust, dirt, and corrosion.
- b. Inspect for damage, such as cracks, distortion, poor etching, etc, as applicable.

6-29. **MECHANICAL PERFORMANCE STANDARDS.** The mechanical performance standards of the radio receiver when subjected to normal use are most easily evaluated in terms of the minimum (electrical) performance standards of the receiver. Normal use implies that the receiver is not subjected to extreme vibration, extremes in temperature and/or humidity, or exposed to dust, dirt, etc. When the receiver is subjected to abnormal use, an evaluation of the abnormalities or damage sustained determine the extent to which the receiver, certain of its subassemblies, or parts require overhaul.

6-30. **LIFE OF THE RECEIVER.** The life of the receiver is directly dependent on the preventive maintenance performed to keep the receiver in its normal mechanical and electrical state. The replacement of functional mechanical and/or electrical parts, subassemblies, etc, will not impair the subsequent life of the receiver.

### 6-31. SERVICE LIMITS.

6-32. The normal mechanical requirements of the receiver do not depend on the maintenance of parts within specific service limits. Improper mechanical functioning of the receiver, after long periods of normal use, may be directly attributable to any one or more of the following conditions.

- a. Accumulations of dust, dirt, sediment, moisture and the resultant corrosion, rotting, etc may cause the mechanical functioning parts of the receiver to become clogged and subsequently worn so that they no longer function normally.
- b. Repeated use and mechanical fatigue may result in the attaching hardware used to assemble the parts and

subassemblies to the receiver loosening up so that the receiver mechanical functioning becomes impaired. Further use may possibly result in damage to functioning parts.

c. Repeated use and mechanical fatigue may cause the numerous springs used in the receiver to no longer provide the necessary tension required for the normal functioning of the receiver.

d. Repeated use under extreme conditions of vibration, temperature, and humidity may accelerate conditions which lead to abnormal mechanical functioning of the receiver.

6-33. Whenever the receiver is subjected to overhaul not directly due to abnormal use of the receiver, the overhaul should include the following checks of the receiver spring complement.

a. Check to see that each of the three contact springs used on the partitions in the tuning unit shield assembly are secure and make positive contact with the turret rotor assembly.

b. Check to see that the wavy washer at the front end of the turret rotor assembly is not loose such that it fails to turn when the turret rotor assembly is indented from one band to the next. A loose wavy washer indicates turret rotor endplay.

c. Check to see that the "U" shaped contact spring at the rear of the turret rotor assembly provides firm wiping contact with the turret rotor assembly and that it is securely mounted.

d. Check to see that the receiver helical spring complement, namely that at the pointer slide, the two at the lever and roller detent assembly, and that at the conversion switch, have not lost their tension. Do this by removing each spring in turn and noting that its unloaded length is normal, i.e., the same as a new spare replacement part.

e. Check to see that the three spider springs at the gear-train assembly are not distorted in any way from their normal unmounted shape by comparing them to a new spare replacement part.

f. Check to see that the 24 r-f tuner subassemblies, the 24 r-f coils mounted on them, the h-f-o crystals, all adjustable turning cores, and all trimmer capacitors, are all provided with sufficient mounting tension from their respective mounting springs, as evidenced by feel.

g. Check to see that the "V" contact springs on the band change switch base and spring assembly are not broken and that they provide contact with the switch pins on each of the r-f tuner subassemblies.

FREE DOWNLOAD  
COURTESY OF  
WWW.HAMMAR

## SECTION VII

### REPAIR AND REPLACEMENT

#### 7-1. GENERAL.

7-2. The radio receiver comprises parts which are not normally repaired. However, all parts comprising the receiver may be replaced. Of these, only the replacement of each of the four base and spring assemblies, comprising parts contained on the r-f strip, requires detailed instructions; refer to paragraph 7-3.

#### 7-3. SWITCH BASE AND SPRING ASSEMBLY.

7-4. To replace any of the four base and spring assemblies comprising the stator of the band change switch, first remove the r-f strip from the receiver. The reason for the replacement may be that one of the six "V" contact springs on the four isolantite bases, or the bases themselves, may be broken.

7-5. To replace a "V" contact spring, remove the defective spring by first removing from the spring terminals the solder which holds the spring in place in the isolantite base. Then spring back the spring ear on each spring leg in turn while pushing in a direction to remove the spring. Note the spring ear locations on the spring to be replaced. A new spring is then substituted for the defective spring removed, solder being used to retain it.

7-6. To replace a base and spring assembly, use the line-up bar (2, figure 2-1) and locating pins (1 and 3) to properly locate the base and spring assembly in relation to the rest of the r-f strip assembly. First, clear the terminals of the isolantite base to be replaced by unsoldering the parts and leads soldered between them and the r-f strip proper. Then unsolder the isolantite base itself by removing the solder from the two eyelets by means of which it is mounted to the r-f strip. Then remove the isolantite base so that a new one may be used to replace it. To properly locate the new isolantite base, position the line-up bar (2) over it and the other isolantite bases contained in the r-f strip. The line-up bar is then located in relation to the isolantite bases soldered

to the r-f strip by means of the locating pins (1 and 3) which fit through the line-up bar holes and into the two holes in each of the isolantite bases. Pin (1) is used in the smaller and pin (3) in the larger of the two holes in each base. Position the new isolantite base so that when soldered into place it is up against the line-up bar as are all others. Remove the eight pins and the line-up bar. Solder, to the new isolantite base, the r-f strip parts and leads previously removed. Dress all leads as they were previously by duplicating an r-f strip kept on hand as a sample.

#### 7-7. SELECTIVITY SWITCH.

7-8. The selectivity switch, which provides three crystal and three non-crystal positions of receiver acceptance bandwidth, is a three-section wafer-type switch assembly which is assembled to the receiver with other parts, as outlined in paragraph 4-7, assembled to it. It is recommended that the switch assembly be replaced as a unit instead of replacing any one of the wafers comprising it. Replacement of a wafer is impractical, since its contact construction assembly is peculiar to the receiver.

#### 7-9. RETROPICALIZATION.

7-10. The soldered joints, r-f coils, and r-f chokes in the radio receiver are all treated with fungicidal varnish to render them moisture and fungus proofed.

7-11. Where the tropicalization of coils and chokes requires some touch-up, use a small brush dipped in moisture and fungus resistant varnish, Specification MIL-V-173, to brush the varnish on the coil or choke, as needed.

7-12. After resoldering a soldered joint, treat it by brushing with varnish to completely cover the soldered joint.

7-13. If any soldered joint is found to be poorly treated with the varnish, it should be retreated to provide complete varnish coverage.

## SECTION VIII

## REASSEMBLY AND TESTING OF SUBASSEMBLIES AND ASSEMBLIES

**8-1. GENERAL.**

8-2. The reassembly of the radio receiver comprises the separate reassembly of the receiver chassis assembly and the receiver tuning unit assembly. The receiver chassis reassembly need not follow a specific step sequence, other than that the main cable wiring assembly be added first and the selectivity switch assembly, referred to in paragraph 4-7, be assembled last to the receiver chassis. The frequency control unit and audio filter assemblies referred to in paragraph 4-8 may be reassembled to the receiver chassis assembly prior to reassembling the receiver tuning unit and chassis assemblies.

**8-3. REASSEMBLY OF TUNING UNIT ASSEMBLY.**

8-4. Before attempting to reassemble the gear-train assembly, it is recommended that the following procedures be understood fully so that the various reassembly requirements are anticipated during the actual assembly. The gear-train assembly (figure 4-1) consists of a tuning unit shield assembly (56) and a mounting disc and shaft assembly (48), which are reassembled subsequent to the addition of the base plate and spider assembly (54) to the tuning unit shield assembly. The gears and parts which comprise the gear-train are then built up on the base plate and spider assembly to completely reassemble the gear-train assembly.

a. Reassemble the tuning unit shield assembly (56), noting that one of the three contact springs (50) is associated with each reinforcing plate of the tuning unit shield assembly. Seat the contact spring on the reinforcing plate prior to assembly, and use the swage (1, figure 2-2) and seat mounting (2) to swage the reinforcing plate metal to properly seat and firmly retain the spring.

b. Reassemble the tuning unit shield assembly (56, figure 4-1) to the base plate and spider assembly (54), using ten screws (55).

c. Reassemble the mounting disc and shaft assembly (48) using the fixture jig (1, figure 2-3), the rod (2), and the spanner wrench (3). Check the alignment of the eight mounting discs by passing the rod through the locating holes in the mounting discs. If the alignment is correct, tighten the assembly with the spanner wrench.

d. Reassemble the mounting disc and shaft assembly (48, figure 4-1) to the tuning unit shield assembly (56). Position the wavy washer (47) at the front end of the mounting disc and shaft assembly. Seat the combination in the tuning unit shield and base plate and spider assembly. Lubricate the hub (44) and screw (49) with lubricating grease, Specification MIL-G-3278, and secure the hub to the front end of the mounting disc and shaft assembly, using three screws (45) and three lockwashers (46).

Then mount the screw (49) which acts as the rear bearing for the mounting disc and shaft assembly. Make certain that the wavy washer is centered on the large nut at the front end of mounting disc and shaft assembly before tightening the two bearings. Lubricate both bearings using lubricating grease, Specification MIL-G-3278. Add the lever assembly (39) and switch spring (38).

e. Use the rod (2, figure 2-3) to line up the mounting disc and shaft assembly (48, figure 4-1) and base plate and spider assembly (54), by means of the alignment holes provided in each assembly. Align the assemblies so that the conversion-switch cam at the rear of the mounting disc and shaft assembly is in its high position when the switch blade of the conversion switch assembled to the tuning unit shield assembly shorts its center contact to the contact nearest to the edge of the tuning unit shield assembly (56).

f. Add the three spider springs (51) to the base plate and spider assembly (54). Add the nut plate (52) to the base plate and spider assembly, using two screws (53).

g. Attach gears (41 and 40) to the hub (44), using three screws (42) and three lockwashers (43). Attach two gears (34) to the plate and pin assembly (37), using two washers (36) and two retaining rings (35); attach the plate and pin assembly (37) to the base plate and spider assembly (54) using two screws (33), but do not tighten the assembly.

h. Attach three mounting posts (24) to the bearing plate (18) with the three screws (25). Lubricate the shaft of the shaft and gear assembly (23) with lubricating grease, Specification MIL-G-3278, and assemble it to the hub (21) using the retaining ring (22). Loosely mount the completed assembly to the bearing plate (18) using three screws (20).

i. Locate one ball bearing (32), lubricated with lubricating grease, Specification MIL-G-3278, at the base plate and spider assembly (54). Attach the bearing screw (15) and nut (16) to the bearing plate (18). Position the ball bearing (17), lubricated with lubricating grease, Specification MIL-G-3278, at the bearing screw (15). Position the gear and drive pin assembly (31) against the ball bearing (17), and mount the bearing plate (18) with the lubricated, loosely-mounted gear and drive pin assembly (31) to the two top posts (24), using two screws (19).

j. Lubricate the five tempered shafts on the base plate and spider assembly (54) with lubricating grease, Specification MIL-G-3278.

k. Position the drive pin of the gear and drive pin assembly (31) at the top of the slot in the base plate and spider assembly (54). Add the gear and hub assembly

(27) to the spider assembly at the top right of the base plate and spider assembly (54), and add the dial, hub and gear assembly (26) to the adjacent shaft. Mesh the gear and hub assembly (27) and the dial, hub and gear assembly (26) so that the stop pin of assembly (26) is radial with the center of assembly (27) and against one of the buttons of assembly (27) when this assembly is turned clockwise. Next position the gear and drive pin assembly (31) so that the drive pin is one tooth away from its position at the top of the slot in the base plate and spider assembly (54), and mesh in this position with the gear and hub assembly (27). With the gears engaged in this manner, install the retaining rings (30) on each of the shafts. Use the pliers (2, figure 2-4) to tighten the retainer rings.

l. Add the gear and hub assembly (28) to the top left spider on the base plate and spider assembly (54), and add the main dial hub and gear assembly (29) to the shaft adjacent to the spider. With the dial, hub and gear assembly (26) adjusted so that its stop pin is against the button stop, as outlined in step k, position the main dial hub and gear assembly (29) so that a straight-edge butted up against the shafts which carry it and the gear and hub assembly (28) bisects the upper tapped hole on main dial hub and gear assembly (29). Add retaining rings (30) to the shafts carrying the main dial hub and gear assembly (29) and gear and hub assembly (28).

m. Add the idler (14) to the bottom spider on base plate and spider assembly (54). Lubricate the shafts of the flywheel and shaft assembly (13) and the shaft and gear assembly (12), using lubricating grease, Specification MIL-G-3278. Assemble the cam and hub assembly (11) to the shaft and gear assembly (12). Mount the completed assembly and the flywheel and shaft assembly (13), using the bearing plate (8), screw (9), and two screws (10).

n. Add the lever and roller assembly (7) with its two detent springs (6). Bring the cam and hub assembly (11) forward to the bearing plate (8), locate the roller in

the cam, line up the cam with the lever and roller assembly (7) arm, and then tighten the setscrews in the cam and hub assembly (11).

o. Check for smooth overall operation, then tighten two screws (33) used to mount the plate and pin assembly (37).

p. Adjust the bearing screw (15) to take up any slack. Be careful not to bend the mounting out during the adjustment.

q. Mesh the gear of the shaft and gear assembly (23) with the gear (40), and tighten three screws (20).

r. Mount the slide and roller assembly (3), using four spacers (5) and four screws (4). Add the slide spring (2).

s. Add the cam and hub assembly (1), locating the dial so that its hairline lines up with that on the jig (2, figure 2-4) when the jig is mounted over the cam and hub assembly (1) on the slide and roller assembly (3) and its mounting.

#### **8-5. RESOLDERING AND RETROPICALIZATION.**

8-6. Reassembly of the radio receiver requires that all electrical wires which were unsoldered to dismantle and disassemble the radio receiver be resoldered. Subsequent to resoldering, each soldered joint must be completely covered with moisture and fungus resistant varnish, Specification MIL-V-173, by brushing each joint with a small brush dipped in same. To maintain performance, all electrical wires and part lead lengths, the electrical wires prewired to subassemblies and parts, their dress and the dress of all parts, and the manner and location of each ground connection must duplicate in each instance the factory techniques incorporated into each radio receiver.

#### **8-7. TESTING OF SUBASSEMBLIES AND ASSEMBLIES.**

8-8. The test procedure used for a receiver subassembly is to reassemble the repaired subassembly or a new one to the receiver and then to test the radio receiver as outlined in the applicable handbook of service instructions.

**SECTION IX****REASSEMBLY AND TESTING OF COMPONENTS****9-1. GENERAL.**

9-2. The reassembly sequence of the radio receiver is to reassemble the subassemblies comprising it separately and then, in turn, to reassemble the subassemblies into an assembly to which is added the bottom plate and top cover.

**9-3. REASSEMBLY OF CHASSIS AND TUNING UNIT ASSEMBLY.**

9-4. The procedure to reassemble the chassis and tuning unit assembly is to add the tuning unit assembly described in paragraph 8-3, including the gear-train assembly and the tuning unit shield assembly, to the chassis assembly in the following manner.

a. Seat the tuning unit assembly into the chassis assembly.

b. Fasten the tuning unit assembly at its rear end to the chassis assembly, using a No. 10-32 machine screw with included external-tooth washer, by passing the screw through the angle bracket on the tuning unit assembly and through the hole in the chassis assembly, and then adding a No. 10 lockwasher and a No. 10 nut to the No. 10-32 machine screw.

c. Fasten the tuning unit assembly at its front end to the chassis assembly, using two No. 10-32 machine screws with included external-tooth lockwasher, and one stud screwed into a spacer post, at either front side of the tuning unit assembly, passing the two screws and the stud through clearance holes in the chassis assembly to screw into the two nut plate brackets used.

d. Resolder two red/green, one green/red, and one yellow/red leads of the main wiring cable to conversion switch S4.

e. Resolder one white/black, one red/white, one blue/red, one yellow/black, and one red/green leads, comprising leads from terminal board E13 adjacent to the filter assembly, to the top terminal strip of mixer plate transformer assembly T1 on the tuning unit assembly.

f. Resolder the two blue/black leads of the tuning unit assembly to second mixer input transformer T2.

g. Resolder the two green/white leads of the tuning unit assembly, one to terminal board E17 at the front of the chassis assembly alongside the selectivity switch, and the other to terminal board E14 normal to the former at the front end of the switch.

h. Retropicalize all soldered joints as outlined in paragraph 7-9.

**9-5. REASSEMBLY OF CHASSIS AND PANEL ASSEMBLY.**

9-6. The procedure to reassemble the chassis and panel assembly is to assemble the receiver front panel assembly to the chassis and tuning unit assembly described in paragraph 9-3, in the following manner.

a. Fasten the front panel assembly to the chassis and tuning unit assembly using eight 1-inch No. 10-32 machine screws, four on each side of the front panel, and two 1/2-inch No. 10-32 machine screws at the bottom of the front panel. The latter screws into the spacer posts used in the reassembly of the tuning unit assembly to the chassis assembly. Each No. 10-32 machine screw has a No. 10 lockwasher added to it.

b. Relocate all toggle switches and the phones jack, and fasten each to the front panel, using the nut removed from the shaft bushing of each during disassembly.

c. Relocate the two flexible couplings to engage their respective shafts contained in the front panel and tighten the setscrews contained in each.

d. Add the r-f gain, tuning, band change, and audio gain knobs to the appropriate control shaft of each and tighten the setscrews contained in each.

e. Assemble the small eccentric, the large eccentric, and tie rod, which together provide the drive assembly for crystal switch S3 located on the base plate of the gear-train assembly, and add the large eccentric to the extension shaft of crystal selector switch S2. Now locate the extension shaft into the fixed coupling at the frequency control unit and through the clearance hole for it in the front panel. Seat the small eccentric on the shaft of crystal switch S3 and locate the tie rod so that it is normal to the extension shaft. Tighten the setscrews in the fixed coupling and those on the small and large eccentrics so that when crystal switch S3 is in its most clockwise position, crystal selector switch S2 is in the first crystal position. Then locate the S2 eccentric drive to the drive end of its groove, back it up slightly, and tighten. Add the small helical spring to crystal switch S3, and the knob to the extension shaft at the front panel.

**9-7. REASSEMBLY OF R-F TUNERS.**

9-8. The 24 r-f tuners or r-f subassemblies are considered part of the tuning unit assembly proper. Even so, they may be reassembled to the chassis and tuning unit assembly, or to the chassis and panel assembly, preferably to the latter. Each r-f tuner has stamped on its steatite base the Hammarlund part/drawing number applicable

**TABLE II. IDENTIFICATION OF R-F TUNERS**

Band No.	Freq Range (Mc)	Hammarlund Part/Drawing No.			
		Input	Interstage		Oscillator
1	0.54-1.35	31387-1	31386-1	31386-1	31385-1
2	1.35-3.45	31390-1	31389-1	31389-1	31388-1
3	3.45-7.40	31393-1	31392-1	31392-1	31391-1
4	7.40-14.80	31396-1	31395-1	31395-1	31394-1
5	14.80-29.70	31399-1	31398-1	31398-1	31397-1
6	29.70-54.00	31405-1	31404-1	31404-1	31403-1

to it. Table II identifies each r-f tuner so that it may be properly reassembled to the chassis and panel assembly of the receiver. For each frequency band the input r-f tuners are reassembled to the rear end of the rotor and mounting disk assembly contained in the tuning unit assembly. Next in reassembly sequence are the two interstage r-f tuners, the oscillator r-f tuner for each band being reassembled to the rotor and mounting disk assembly nearest to the front panel of the receiver. When making the reassembly, the r-f tuners are reassembled to the one of the two most exposed positions of the rotor and mounting disk assembly as viewed from the bottom of the receiver, so that when the band change control knob on the front panel is turned clockwise, the reassembled r-f tuners move to the other most exposed position of the rotor and mounting disk assembly. The reassembly of the band No. 4 r-f tuners is made with the band change dial set for band No. 1, so that when the band change control knob on the front panel is turned clockwise the r-f tuners for band No. 5, 6, 1, 2, and 3 are reassembled in sequence.

**9-9. REASSEMBLY OF PLUG CONNECTOR ASSEMBLIES.**

9-10. Prior to reassembly of the radio receiver as outlined in paragraph 9-11, connect the three receiver plug

connector assemblies to the receiver chassis and panel assembly, as outlined in the applicable handbook of service instructions. P2 is a type UG-102/U plug connector; P3 a type UG-104/U angle plug adapter; and P4 a type PL-259 plug connector.

**9-11. REASSEMBLY OF RADIO RECEIVER.**

9-12. The final step in the reassembly of the radio receiver is to add the bottom plate and the top cover to the chassis and panel assembly in the following manner.

- a. Reassemble the bottom plate using seven No. 10-32 machine screws with included external-tooth lockwashers.
- b. Reassemble the top cover, including a rubber packing strip, by butting the rubber packed end of the top cover up against the panel of the chassis and panel assembly while tightening the four thumb screws. Each screw passes through one of the four mounting brackets which form part of the top cover proper.

**9-13. TESTING.**

9-14. After reassembly, align and adjust the chassis and panel assembly in accordance with the instructions outlined in the applicable handbook of service instructions. The receiver is also tested with regard to the minimum performance standards specified for it therein.

## SECTION X FINAL REASSEMBLY

10-1. The reassembly of the radio receiver, as outlined in Section IX, comprises the final reassembly of the complete equipment.

## SECTION XI INSPECTION, TESTING, AND PACKAGING

### 11-1. GENERAL.

11-2. The complete radio receiver is aligned, inspected, and tested as outlined in the applicable handbook of service instructions.

#### Note

Markings of equipments required by Government T.O.'s or other instructions, to indicate overhaul or the incorporation of changes shall be applied during inspection and test (if not previously applied to subassemblies, assemblies, or components during overhaul and assembly).

### 11-3. MINIMUM PERFORMANCE AND TEST VALUES.

11-4. The minimum mechanical performance and electrical test standards applicable to the radio receiver, are

those outlined and specified in the applicable handbook of service instructions. No tolerances are applicable to the mechanical performance of the receiver. The electrical test standards specified for the receiver may be exceeded but never "opened up" to provide for acceptance of a specific receiver. The performance of each radio receiver, used in an operational activity comprising other electronic equipment, duplicates that of the receiver as separately inspected and tested to conform to its minimum performance and test values. Adequate shielding incorporated into the receiver design precludes the possibility of receiver radiation to any associated equipment.

### 11-5. PACKAGING.

11-6. The radio receiver is packaged for shipment in accordance with the instructions outlined in the applicable handbook of service instructions.

## SECTION XII DIFFERENCE DATA SHEETS

(NOT APPLICABLE)